

16th ABU DHABI WOUND CARE CONFERENCE

in collaboration with



INTERNATIONAL INTERPROFESSIONAL
WOUND CARE GROUP &
SHEIKH KHALIFA MEDICAL CITY-ABU DHABI



مستشفى
SEHA



Abu Dhabi National Exhibition Centre (ADNEC) Abu Dhabi, UAE | 10 - 11 April 2025

EXHIBITOR MANUAL

Abu Dhabi National Exhibition Centre (ADNEC)
10-11 April 2025



EXHIBITOR MANUAL

Dear Valued Exhibitors,

We extend our warmest greetings and appreciation for your participation as exhibitors at the upcoming **16th Abu Dhabi Wound Care Conference**, in collaboration with the **International Interprofessional Wound Care Group (IIWCG) & Sheikh Khalifa Medical City (SKMC)**, Abu Dhabi will be held from April 10-11, 2025, at the prestigious Abu Dhabi National Exhibition Center (ADNEC), your presence is integral to the success of this landmark event. We are thrilled about our collaboration and are committed to ensuring a seamless process and an unforgettable experience for all.

To facilitate your exhibition journey, we present the Exhibitor Manual, a meticulously crafted guide designed to be your go-to resource for comprehensive assistance. This manual includes crucial information from the Congress organizer and exhibition service providers, offering insights to address your pre-event and onsite queries. It is a comprehensive document that outlines everything you need to know, from claiming your exhibitor entitlements before the event to fulfilling your role as an exhibitor. We encourage you to share this manual with contractors or stand builders to ensure smooth compliance with the requirements.

Warm regards,

ADWCC Team

**CONTACTS
(ORGANIZER)**

bince@smacuae.com

TABLE OF CONTENTS

[SECTION 1: Official Contractors List & Service Order Form Deadlines](#)

[SECTION 2: Exhibition Schedule](#)

[SECTION 3: General Information](#)

[SECTION 4: Onsite Facilities](#)

[SECTION 5: Space Only Stand Build Regulations](#)

[SECTION 6: Shell Scheme Specifications, Rules & Regulations](#)

[SECTION 7: Official Contracting Services Forms and Venue Forms](#)

SECTION 1: OFFICIAL CONTRACTORS & SERVICE ORDER FORM DEADLINES

SECTION 1: OFFICIAL CONTRACTORS

Audio Visual

Company Name: **ADNEC Services**

T: +971 (0) 2 406 3666

F: +971 (0) 2 449 9770

E: adnecservices.oc@adnec.ae

Catering

Company Name: **Capital Catering + Services**

T: +971 (0) 2 444 6900

F: +971 (0) 2 444 6135

E: sales@capitalcatering.ae

Freight Forwarding, Customs Clearance & On-site Handling

Company Name: **DSV Logistics / DSV Fairs & Events LLC**

www.dsv.com



Contact: Nilofer Sayeed Mobile : +97156 6833914 E-mail : nilofer.sayeed@dsv.com	Contact: Nomar Pavon Mobile : +971 55 9171107 E-mail : nomar.pavon@dsv.com
--	---

IT & Communications

Company Name: **ADNEC Services**

T: +971 (0) 2 406 3666

F: +971 (0) 2 449 9770

E: customer.services@adnec.ae

Shell Scheme, Shell Scheme Electric, Furniture and Floor Covering / Signage & Graphics

Company Name: **ADNEC Services**

T: +971 (0) 2 406 3666

E: adnecservices.oc@adnec.ae

Mains & Rigging for Space Only Stands

Company Name: **ADNEC Services**

T: +971 (0) 2 406 3666

E: adnecservices@adnec.ae

Stand Cleaning

Company Name: **ADNEC**

T: +971 (0) 2 406 3666

F: +971 (0) 2 449 9770

E: customer.services@adnec.ae

Shell Scheme Order Form		
Form 1	AV Order	Optional - if you'll require, audio visual for your stand
Form 2	Carpet Order	Optional - If you wish to change the colour of your carpet which is included in your package
Form 3	Furniture Order	Optional - if you'll require additional furniture
Form 4	Shell Scheme Electric Order	Optional - if you'll require additional socket and other electrical accessories
Form 5	Stand Fitting Order	Optional - if you'll require additional panel and other sand fitting services
Form 6	Fascia Order Form	Mandatory - this is the name board + stand no. to be place on the top board of your booth - if you ordered fascia logo or seamless fascia on graphics order form, no need to submit this form.
Form 7	Graphics Order form	Optional but recommended - to enhance your shell scheme booth and to provide opportunity for branding/marketing.

*Please order through the exhibitor portal, for further assistance please contact our official contractor, ADNEC Services at adnecservices.oc@adnec.ae

Other venue services such as: Static security, IT, stand cleaning can be ordered through ADNEC venue. For further assistance please contact customer service at customer.services@adnec.ae

APPLICABLE TO SPACE ONLY

TASKS/FORMS	HOW TO SUBMIT/ORDER	EMAIL
Stand plan submission	Mandatory	bince@smacuae.com
FORM 8 - Mains & Water supply	Mandatory	adnecservices@adnec.ae
Contractor Pass & Vehicle Access	Mandatory	customerservices@adnec.ae
FORM 9 - Rigging	As required only.	adnecservices@adnec.ae
Catering	As required only.	sales@capitalcatering.ae

SECTION 2: EXHIBITION SCHEDULE

SECTION 2: EXHIBITOR SCHEDULE

BUILD-UP		
DATE	TIME	INSTRUCTION
Wednesday, April 9, 2025	08:00 to 20:00	SPACE ONLY STANDS All space only stands should be complete by Wednesday, April 9, 2025 @ 20:00
CONFERENCE DAYS		
DATE	SHOW OPEN TIMES	EXHIBITOR ACCESS TIMES
Thursday, April 10, 2025	8:00 to 17:00	8:00 to 17:00
Friday, April 11, 2025	8:00 to 17:00	8:00 to 17:00
BREAKDOWN		
DATE	TIME	INSTRUCTION
Friday, April 11, 2025	After 18:00 to 12 Midnight	Start time for all Space Only stands to be dismantled and removed

SECTION 3: GENERAL INFORMATION

SECTION 3: GENERAL INFORMATION

3.1 Venue Information

The 16th ADWCC will take place at ADNEC which is positioned in the Capital City's Diplomatic District between Khaleej Al Arabi Street and Airport Road.

ADNEC is conveniently located 20 minutes from Abu Dhabi City Centre / Corniche, 15 minutes from the Abu Dhabi International Airport and 45 minutes from Jebel Ali, Dubai.

For further information about ADNEC please visit www.adnec.ae
You may also visit our venue virtually via the below link:

<https://www.adnec.ae/shared/virtualtour/index.html>

The 16th ADWCC will occur in Conference Hall A & B, Atrium & Link. The Exhibition area is located in Atrium & Link.

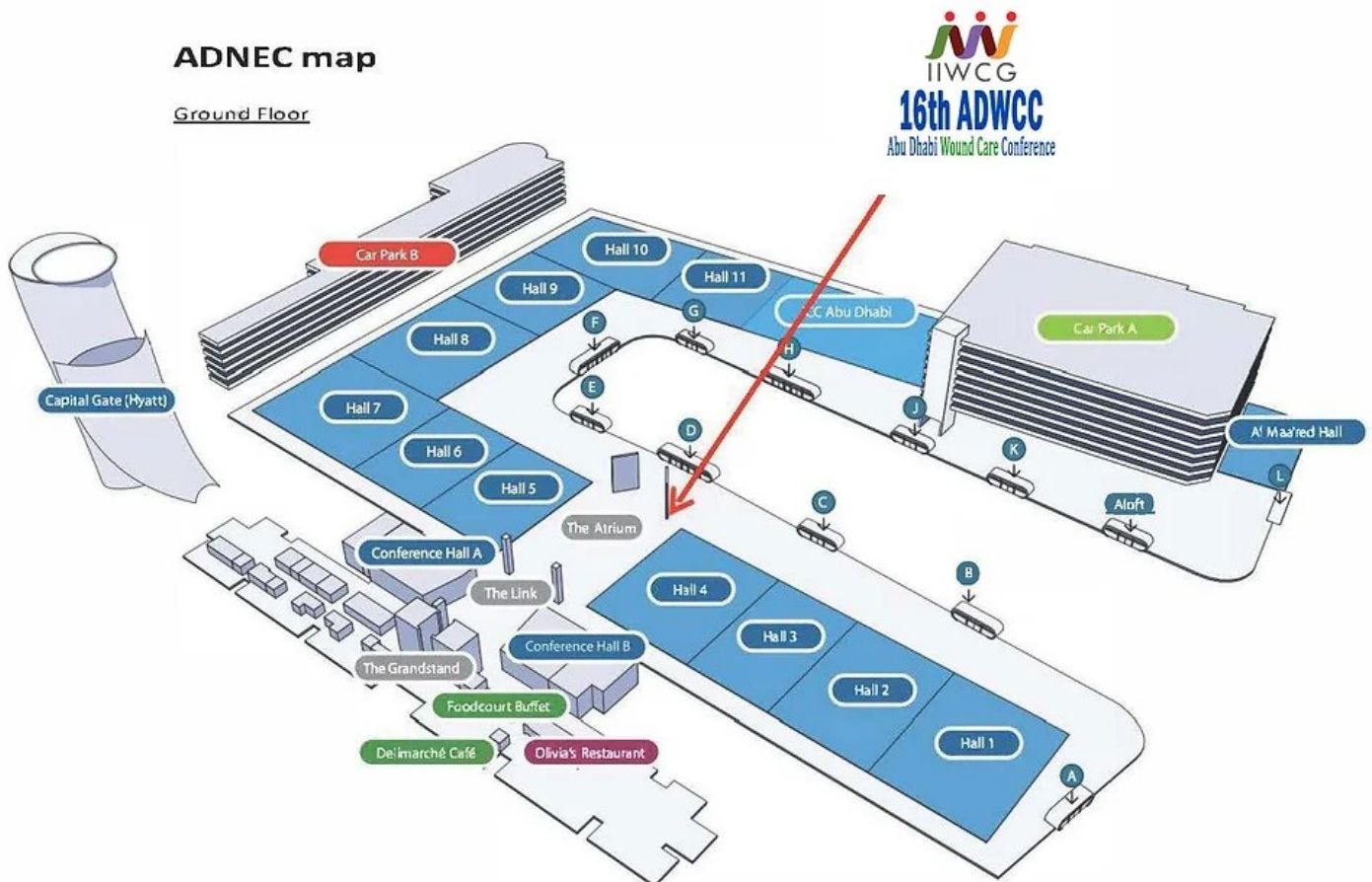

3.2 Promotional Material

Please be sensitive to the content of any promotional material that you are planning to use at the exhibition. It is important that such material is not offensive to the Cultural and/or religious values and sensitivities of the people of the United Arab Emirates. If in doubt about any material that you are considering using, please do not hesitate to contact the operations team and they will be able to provide clarification on this if necessary.

3.3 Distribution of Material / Canvassing

It is prohibited for exhibitors (or staff members working on behalf of exhibitors) to display or distribute any material (in any form) from any other areas other than within the boundary of their stand. This restriction also applies to the gangways surrounding your stand.

3.4 Insurance

The exhibitor is fully responsible for obtaining insurance protection for his exhibits, property and personnel against all risks as stated in the Terms and Conditions of their Contract. Equipment should be insured both in transit and on location at the exhibition site for the entire period of the exhibition.

Exhibitors are fully responsible for the security of their exhibition booth and equipment. The materials are advised not to be left unsecure on the stand inside the exhibition hall at the end of the day or after the exhibition closes. Organisers provides general security of the venue and the exhibition area. However, they will not be held responsible for the security of the booths and their contents for damage to, or theft of any goods.

Insurance cover should include:

- Personal Injury
- Third Party Claims
- Expenses incurred and/or losses of any kind, including losses resulting from the abandonment or postponement of the exhibition.
- Medical expenses and baggage cover
- Value of the stand, including the fittings
- Such insurance must be a minimum of 14,000,000.00 AED.

3.5 Visa Regulations

Nationals of the following countries will be issued, free of charge, with an entry visa valid for 30 days at passport control upon arrival in the UAE

Andorra	Argentina	Australia	Austria	Bahamas
Barbados	Belgium	Brazil	Brunei	Bulgaria
Canada	Chile	Colombia	Costa Rica	Croatia
Cyprus	Czech Republic	Denmark	Estonia	Finland
France	Germany	Greece	Honduras	Hong Kong (SAR of China)
Hungary	Iceland	Ireland	Italy	Japan
Kazakhstan	Latvia	Liechtenstein	Lithuania	Luxembourg
Malaysia	Maldives	Malta	Mexico	Monaco
Montenegro	Nauru	Netherlands	New Zealand	Norway
Republic of China	Peru	Poland	Republic of Mauritius	Republic of El Salvador
Portugal	Romania	Russian	United States of America	San Marino
Serbia	Seychelles	Singapore	Slovakia	Slovenia
Solomon	South Korea	Spain	Sweden	Switzerland
The Vatican	Ukraine	United Kingdom	Saint Vincent and The Grenadines	Uruguay

Subject to UAE laws, some countries are permitted Visa on Arrival, free of charge, with an entry visa valid for 30 days at passport control upon arrival in the UAE.

Please note that a visit visa does not entitle the visitor to take up permanent work in the UAE. Other nationalities are solely responsible for obtaining visas for themselves, their representatives, and invitees. The organisers are not in a position to sponsor visa applications.

Visas can be arranged through travel agents and hotels, provided sufficient time is given for the application to be processed. Please be aware that the issuing of visas can be quite a lengthy process and that you must have a passport that is valid of at least 6 months from departure.

It is essential that all working personnel check, prior to departure from their homeland, that they do not require a visa. Visa processing can be applied for via Registration Online or to your nearest UAE Embassy.

SECTION 4: ONSITE FACILITIES

Site Facilities, Supplementary Services & Site Access

4.1 Site Facilities

Exhibitors Information Desk	Customer Care Centre	Prayer Facilities
Official Contractors Offices	Exhibition Security	Restaurants
Visitor Reception & Visitor Registration	Car Parking	Taxi Services
Media Centre	Internet Access	Toilets
Press Conference Rooms	Medical Centre	First Aid



4.2 Customer Service

A Customer Service Unit will be located on site. ADNEC Customer Service is situated at the end of the Atrium.

The centre will be available during show hours and provide the following range of services:



- Printing
- Photocopying
- Scanning
- Fax
- Free Wifi onsite (limited access only)
- IT & TELECOMMUNICATIONS

ADNEC provides the following telecommunications and data services:

1. International Phone Line & Set
2. International Fax Line with machine
3. Internet connection

All the above services can be ordered through the IT & Telecommunication order form.

- Binding
- Lamination
- AV
- Cleaning
- Security
- Catering
- Parking
- Exhibition Visa
- Furniture & Miscellaneous Items
- Labour Order
- Skip

	<p>4.3 People of Determination</p> <p>All exhibition halls, meeting rooms and public areas will have access for people of determination. There are also designated toilets on site which are clearly signposted. An allocation of parking bays will be reserved for drivers with special needs.</p> <p>Please visit the website: www.adnec.ae</p>
	<p>4.4. Fire Appliances and Information</p> <p>Fire extinguishers of approved pattern and capacity can be found at various locations around the site according to the risk involved – instructions will also be supplied, please locate your nearest extinguisher. Exhibitors will be given instructions regarding fire, emergency, and accident procedures prior to the show opening, please ensure all personnel read these carefully.</p> <ul style="list-style-type: none"> • Please ensure that you familiarize yourself with the Fire and Emergency Procedures in the Health & Safety section. • In accordance with regulations and standard procedures, fire extinguishers will be distributed at the Fire Officer’s discretion. • These may not be moved under any circumstance – Exhibitors will be charged for loss or damage to these extinguishers. • Please ensure that at least two stand personnel are familiar with the use of Fire Extinguishers. • Fire Exits and Extinguishers / Fire Hose points must never be blocked. • No paint or paint thinner can be placed near the electrical distribution boxes. <p>Empty cartons/boxes, catalogue boxes, stand materials and combustible waste must be disposed of and not stored behind stands.</p>
	<p>4.5 First Aid Services</p> <p>There are a number of First Aid facilities located in the venue.</p> <p>In the event of an emergency at any time please call the Control Room; +971 (0) 2 406 4444.</p>

SECTION 5: SPACE ONLY STAND BUILD REGULATIONS

SECTION 5: SPACE ONLY

5.1 Stand Space and Exhibitors' Responsibilities

Space only exhibitors are responsible for their own stand design and construction. No stand fittings or carpet is provided by 16th ADWCC organizers on space only sites. All space only stand designs **must be approved by the organizers** before building their stand. Stand submission should be sent by email to: bince@smacuae.com

Contractor & Vehicle Access

Charges are levied to all contractors and vehicles requiring access to the venue during Build-up and Break-down:

- All contractors must be able to present their Emirates ID card together with a photocopy of their UAE visa showing their sponsor's name. Only a valid Emirates ID card together with a copy of the visa will permit access into ADNEC.
- All contractor staff must report to the nearest loading bay to avail the maintenance contractor's wristband.
- International contractors will be required to present their passport with a valid UAE visa.

The charges applied will be as follows:

DESCRIPTION	RATE (AED)
<u>Maintenance Contractor Access:</u>	
1 Day (per pax)	25
3 Consecutive Days (per pax)	55
5 Consecutive Days (per pax)	90
3 Consecutive Months	330
Annual	550
Show Contractor (during and after the open days)	225
<u>Vehicle Access:</u>	
Car (30 minutes)	25
Pick-up 3 Tonne (45 minutes)	35
7.5 Tonne (60 minutes)	45
40 foots trailer 18.5 tonne / Artic (60 minutes)	55
Exceeding Hours (all vehicles) / 60minutes	25

5.2 Complex Structures

A complex structure is any form of construction of any height, which would normally be designed by an engineer and/or has, through a risk assessment, been found to provide significant risk. Structures over **4 metres in height**, multi-level stands, raised platforms and all suspended items are generally considered to be complex structures. In addition to this, any stand with a travel distance to a main show gateway or exit from the stand exceeding 10m will be considered a complex structure. Furthermore, Sound/Lighting towers, Temporary tiered seating i.e., Grandstands, Platforms, and stages over 0.6m in height and all platforms and stages for public use, Cantilevers, Long spans, and Seminar Theatres with 15 or more seats, all are considered complex structures.

For all stands exceeding 4m in height, with two-storeys, with a platform exceeding 600mm in height, or deemed by us to be complex structures, drawings must be submitted in English in duplicate (2 copies) to the operations team for approval. These may be submitted electronically as DWG, JPEG or PDF format through the stand plan submission section on the exhibitor portal. The Operations Team will liaise with you to confirm all details.

These drawings must show the form and dimension of every structural member with appropriate general arrangement plan, sections, and elevations, including full details of stairways. All calculations of loading and strength must be in English, and all drawings must be to scale. A risk assessment and method statement are also required.

All complex structures are subject to a pre-show plan approval and onsite inspection by **16th ADWCC** appointed ADNEC structural engineer.

5.3 Double Storey Stands.

Double Storey design submission guidelines:

- Design calculation for beam columns and base plate
- Connection detail and design
- General layout and location of the structures
- Staircase details including handrail details
- Total load
- Structure detail (material)
- ONLY a minimum 400mm x 400mm x 12mm mild steel base plates will be accepted

Staircases

Staircases – should be 2m wide minimum for two-way use considering the safety protocol. Each step shall have an available tread, measured on plan, of 280mm; the risers between steps shall be unfilled and shall not exceed 180mm. Any handrail(s) or balustrades must have vertical railings not more than 100mm apart or solid infill.

Staircases shall discharge to the ground floor at a point where unimpeded access to a public gangway is achieved. If the occupants of the upper storey have no choice but to exit by way of a single escape stair, the travel distance from any part of the storey to that stair must not exceed 10m.

5.4 Height Limit

Single-Story Space Only Stands: The overall height of stand fitting for single-story stands including cladding of columns is 4m from the floor level.

Peripheral walling, if more than 1m high, must not occupy more than one-third of any one side.

Double-Decker Space Only Stands: A maximum height of 6m. Please note that double storey construction is only permitted on island sites. These must have been booked and paid for directly with the relevant sales manager. Exhibitors who have not booked a double-decker stand will not be permitted to build two-storey or exceed the 4metre height limit without the operations team's approval.



5.5 Enclosed Stands

The inclusion of large, enclosed areas within a stand can only be permitted with the organizers prior written permission, please also refer to section 6.7 'Walling in on Open Sides.'

5.6 Dividing Wall

On divided sites, you are responsible for erecting and decorating side and back walls facing onto your stand areas to a height of 2.5m. Walls above this height must be clad and decorated on both sides, with the reverse side being decorated from 2.4m upwards by the exhibitor who has them erected. Such walls overlooking adjoining stands must be finished in a neutral plain colour only. The minimum height for dividing walls is 2.5m.

5.7 Island Stands / Walling in on Open Sides

Space only exhibitor who booked 4 sides open are not allowed to have long runs of walling along open perimeter sides. All sides must be accessible, and guidelines must be observed as follows:

- Only a third of each side of an Island Stand can be blocked.
- Full length of low walling up to 1mH can be accepted, please make sure to have a proper entry and exit access.
- Closed room/partition are suggested to be centralized to avoid blockage of neighbouring stand.
- Solid walls must be combined with glass panels.

5.8 Risk Assessment and Method Statement

All contractors/exhibitors are required to submit a full risk assessment for the design, construction, and arrangement of their stand. If required, please contact the organizers for further information.

The risk assessment is to be submitted along with stand plans. Should you require assistance with producing a risk assessment and method statement, please contact Operations Team at adnecservices.oc@adnec.ae



Stand Plan Submission Summary Procedures:

Please note that all submissions should be made to: bince@smacue.com The following documents are mandatory, and approvals cannot be granted until all documents have been received and fully checked:

- A full set of design drawings, including 3D visuals/renders and technical drawings with all measurements shown.
- Structural calculations for stands above **4 metres in height**.
- Method statement (the form must have company stamp, signature and be on company letterhead).
- Risk assessment (the form must have company stamp, signature and be on company letterhead).
- Proof of insurance for the stand build company (valid contractors all risk insurance with public liability certificate - applicable to Stand Contractors / Stand Builders only)
- Valid Trade Licence (applicable to Stand Contractors / Stand Builders only)
- Stand Plan Checklist Form for Single or Double Storey Stands (form will be provided by the Organiser)

DEADLINE: 4 weeks before build-up

NOTE: All the above forms must be in PDF format, maximum size per file should not exceed 9.5MB.

5.9 Electrical Installations

Mains supply to space only sites is **NOT** included as part of the stand booking and must be ordered to adnecservices@adnec.ae

Mains supply to space only sites is not included within the space rental charge, only the cost of power consumed is included. The official contractor appointed by the organizers are the only individuals permitted to conduct electrical installations. The official contractor for electrics to space only stands is ADNEC Services.



5.10 Open Corners

Open corners of stand floors and platforms must be rounded or angled to avoid sharp corners and tripping hazards.

5.11 Gangways and Emergency Exits

It is imperative that the venue emergency access gangways and fire escapes remain clear at all times. Plans showing emergency routes can be obtained from the organizers' Office. During the build-up and breakdown periods of the exhibition the gangways can become extremely congested with packing cases, equipment, and general waste – in the interests of health & safety, we request that all exhibitors and contractors cooperate with our floor managers and official show contractors to help maintain the emergency access points and gangways at all times.

5.12 Water Supply

Please be aware that a water supply is only available within the exhibition halls where there are floor ducts below the stand space.

5.13 Waste Management

All exhibitors and contractors must ensure that they do not discard sharp objects and must ensure that nails and screws are not left sticking out of waste wood – these must be removed or hammered flat. **16th ADWCC** organizers are committed to ensuring that the exhibition is as environmentally responsible as possible. Please help us by keeping waste to a minimum, recycling waste where possible and reporting any incidence of fly tipping to the organizer.

Only Skips issued by ADNEC's appointed waste contactor are allowed in the Exhibition Halls. All unauthorized skips will be removed at the cost of the exhibitor. Skips can be provided on hire with 48 hours' notice.



5.14 Exhibition Schedule

Please refer to the [Exhibition Schedule](#) for the build-up and breakdown schedule.

The design of your stand must be such that it can be erected and dismantled within the published build up and breakdown periods.

It is important you contact the operations team if you foresee any problems keeping to this schedule. It is the responsibility of the exhibitor or their appointed contractor to ensure the stand is being built to the correct floor markings. Please check with the organisers' office if you are in any doubt regarding your allotted floor space.

5.15 Maintenance

All contractor personnel requiring access to the exhibition site **during** the show must have a **maintenance contractor badge**.

5.16 Working at Height

Ground access to areas in the vicinity of any work at height must be controlled to prevent persons walking or working directly beneath the area in question. Ground workers in the vicinity must not work directly underneath and wear suitable head protection (e.g., hard hats)

Ladders must be footed or tied off and used in accordance with construction regulations. The use of domestic ladders and steps is strictly forbidden.

5.17 Insurance Regulations

The exhibitor is totally responsible for obtaining insurance protection for his exhibits, property and personnel against all risks as stated in the Terms and Conditions. Equipment should be insured both in transit and on location at the exhibition for the entire period it is on the exhibition site Insurance cover should include:

- Personal injury
- Third party claims
- Expenses incurred and/or losses of any kind, including losses resulting from the abandonment or postponement of the exhibition
- Medical expenses and baggage cover
- Value of the stand, including the fittings
- Such insurance must be a minimum of 14,000,000.00Dhs.



Please note the following when designing your stand:

- Ensure that your stand incorporates enough space for wheelchair access - 1.2 metres aisle width is deemed sufficient – though only 750mm for an internal door – suggesting that 750mm would be enough.
- The gradient of any ramp should be no greater than 1:12.
- If a stand is a double-decker, then it is probably not practical to offer lifts. Therefore, please ensure that any services – such as refreshments can be brought downstairs on a tray for those that need it.
- Serving counters should have a low access point no higher than 760mm or a lap tray should be provided for the convenience of disabled people.

5.18 Venue Regulations

Immigration & Labour Law Notice (UAE Government)

As per UAE Law, it is responsibility of the exhibitor/contactor to ensure that all personnel working onsite, during build-up / show days and breakdown carry their relevant documentation, as proof of position in your company.

UAE Labour Law prohibits the hiring or contracting of any illegal labour. Violation of this law may result in a fine of up to AED 200,000 per person.

- The UAE Immigration Control Department make regular unannounced inspections at ADNEC.
- ADNEC Security are responsible for the access control to the building.
- ADNEC's Surveillance Team was created as a safety net in an attempt to prevent any such spot checks finding illegal workers on the premises. ADNEC's main aim is for you and your exhibitors to have a smooth and successful Build Up, Open Period and Break Down.
- The UAE government has phased out Labour cards, effective from 2015. Therefore, ALL labourers must be able to produce their Emirates ID card together with a photocopy of their UAE visa showing their sponsor's name.
- Only a valid Emirates ID card together with a copy of the visa will permit access into ADNEC
- Any other cards will NOT permit access (driving license, medical card, etc.).
- International guests will be required to supply a copy of their temporary visa.

5.19 Safety

ADNEC requires all operators working on access equipment to wear head protection and harnesses and to be attached to the equipment by means of a safety harness. All equipment must be visibly marked with the name of the company using it. N.B. contractors will not be allowed access into the halls without proper footwear. No slippers / sandals are permitted during build- up & breakdown.

In the case of a security emergency or if you see anything suspicious, call the venue emergency number. Co-operate fully with any instructions you may be given.

In the case of a security emergency or if you see anything suspicious, call the venue emergency number. Co-operate fully with any instructions you may be given.

E: security@adnec.ae T:
+971 (0) 2 406 4444

5.20 Mandatory personal protective equipment requirements **Mandatory**

Foot Protection It is now mandatory to wear SAFETY Footwear (Safety shoes with toe and puncture protection) to work in the halls and loading bays during build up and break down periods. Below are the samples for reference purposes only.

Safety Sandals (UAE Nationals / Ladies)



Normal Safety Shoes with Toe and Puncture protection



Mandatory ramp and safety signage for slip and trip hazard areas

Wherever there are trailing cables in gangways during any period open to the public, it is a mandatory requirement that safety ramps are provided in a **Distinctive/High Visibility** color, supported by hazard tape and safety caution signage. (Please see example below)



In the case of a security emergency or if you see anything suspicious, call the venue emergency number. Co-operate fully with any instructions you may be given:

E: security@adnec.ae

T: +971 (0) 2 406 4444



5.21 ADNEC Hall Specifications

Hall Height	10 m
Floor Load	1,000kg /Sqm
Floor Finishing	Reinforced

Structure	Concrete + Steel Frame
Lighting	Spotlights
Air Conditioning	Central

IMPORTANT: Any Space-Only stands exceeding 4m in height must submit structural calculations for stand approval. **Deadline: Four weeks before build-up.**

IMPORTANT: All stands, equipment, merchandise, and waste (stickers, carpet, etc.) absolutely must be removed before end of dismantling.

Once the fitting deadlines have passed, the organiser may, **at the cost and liability of the exhibitor**, take any measures deemed useful to dispose of the remaining equipment and waste on the pitch, as well as the destruction of structures and decoration of any kind that have not been dismantled.

RECOMMENDATION:

If you outsource decorator services, be sure that your quote includes fitting, dismantling and waste removal and add them if they are not featured on the quote.



SECTION 6: SHELL SCHEME SPECIFICATIONS, RULES, AND REGULATIONS

SECTION 6: SHELL SCHEME SPECIFICATIONS, RULES, AND REGULATION

6.1 Shell Scheme Exhibitors

If you have contracted for a shell scheme stand, please find what is included within that package below:

PACKAGE FOR 9 SQM

Carpet	Round Table	White chairs	Reception counter with graphics	Fascia Logo	Waste Basket	Spotlights	Socket
9 sqm	1	2	1	1 per open side	1	3	1

PACKAGE FOR 18 SQM

Carpet	Round Table	White chairs	Reception counter with graphics	Fascia Logo	Waste Basket	Spotlights	Socket
18 sqm	2	4	2	1 per open side	2	6	2



6.2 Visual & Dimensions of a Shell Scheme Stand

The official contractor will be responsible for the erection of the official shell scheme. A full management and technical service will be always provided onsite.

Exhibitors occupying shell scheme stands must ensure that all internal stand fitting and displays are contained within the shell scheme structure and do not exceed the stand height.

Exhibitors may affix lightweight photographs and technical information sheets etc direct to the shell scheme walls with good quality double-sided adhesive pads or similar, provided such material can be removed without damage to the wall panels, any damage made to the panels will result in a charge.

6.3 Shell Scheme Stands (Island)

Wall panels are not generally provided for island sites.

16th ADWCC appointed contractor ADNEC Services will have an onsite service office located within ADNEC reception building throughout build-up should last minute furniture orders and stand fitting extras be required. However, please note that there will only be a limited stock available.



SECTION 7: OFFICIAL CONTRACTING & VENUE FORMS

SECTION 7: OFFICIAL CONTRACTING & VENUE FORMS

ADNEC SERVICES FORMS

1. AUDIO VISUAL & TV
2. CARPET
3. FURNITURE
4. SHELL SCHEME ONLY - ELECTRICAL
5. SHELL SCHEME ONLY - STAND FITTING
6. SHELL SCHEME ONLY – FASCIA (MANDATORY FOR SHELL SCHEME STAND)
7. GRAPHICS/ BRANDING
8. SPACE ONLY - ELECTRICAL/POWER SUPPLY
9. SPACE ONLY – RIGGING

ADNEC VENUE FORMS

1. CONTRACTOR AND VEHICLE ACCESS
2. PARKING
3. SKIP HIRE
4. STAND CLEANING
5. STATIC SECURITY
6. TELECOMS & IT SERVICES
7. VEHICLE CLEANING (FOR CAR DISPLAY)



Tel +971 (0) 2 406 3666

P.O. Box 5546 Abu Dhabi



Fill & Return
adnecservices.oc@adnec.ae



Best Price
when you pay 15 days
before the event



Standard Price
within 14 days or less prior
to the build-up days



Deadline
Submissions close 15 days prior to
the show, thereafter delivery cannot
be guaranteed and standard/on-site
price will apply

EXHIBITOR DETAILS:

Exhibiting Company Name: _____

Date: _____ Hall No. _____ Stand No. _____

** It is the exhibitor's responsibility to inform ADNEC Services of any changes to the stand number / service location.*

ORDER CONTACT DETAILS:

Full Name: _____

Job Title: _____

Company Name: _____

Company Address: _____

City: _____

Postal Code: _____

Country: _____

Contact No. _____

Email Address: _____

On-site Contact Name: _____

On-site Contact No. _____

** It is important to review TERMS AND CONDITIONS attached on this order form before submitting your order.*

INVOICE BILLING DETAILS:

Tax Registration No: _____

Same As Above

Preferred Invoice Currency USD AED

Full Name: _____

Job Title: _____

Company Name: _____

Company Address: _____

City: _____

Postal Code: _____

Country: _____

Contact No. _____

Email Address: _____



ADNEC SERVICES LLC
OFFICIAL CONTRACTING
AUDIO VISUAL ORDER FORM 2024



NOS.	ITEM	UNIT PRICE (AED)			QUANTITY	TOTAL
		BEST PRICE <i>15 days prior to the event</i>	STANDARD PRICE <i>14 days or less prior to the build-up days</i>	ONSITE PRICE <i>during build-up days</i>		
DLP projectors						
1	9000 Ansi Lumens DLP Projector	15,918.00	19,101.00	21,967.00		
2	6 x 8ft ff Screen	579.00	695.00	800.00		
3	7.5 x 10ft FF Screen	993.00	1,191.00	1,370.00		
4	9 x 12ft FF Screen	1,133.00	1,359.00	1,563.00		
Plasma Screens						
5	103" Plasma Screen with DVD player	16,538.00	19,845.00	22,822.00		
LED Screens						
6	24" LED Screen + Floor Stand	656.00	788.00	906.00		
7	32" LED Screen + Floor Stand	911.00	1,093.00	1,257.00		
8	40" LED Screen + Floor Stand	1,076.00	1,291.00	1,485.00		
9	50" LED Screen + Floor Stand	1,146.00	1,376.00	1,582.00		
10	55" LED Screen + Floor Stand	1,886.00	2,263.00	2,603.00		
11	65" LED Screen + Floor Stand	3,750.00	4,499.00	5,174.00		
Stands						
12	Floor Stand for Plasma Screen / LCD Screens	166.00	199.00	229.00		
Touch Screen						
13	22" Touch Screen with Laptop	1,050.00	1,260.00	1,449.00		
14	32" Touch Screen with Laptop	2,580.00	3,096.00	3,561.00		
15	42" Touch Screen with Laptop	3,584.00	4,300.00	4,945.00		
Multi Touch Screen						
16	42" Multi Touch Screen	4,300.00	5,160.00	5,934.00		
17	55" Multi Touch Screen	5,733.00	6,880.00	7,912.00		
18	65" Multi Touch Screen	7,000.00	8,340.00	9,660.00		



**ADNEC SERVICES LLC
OFFICIAL CONTRACTING
AUDIO VISUAL ORDER FORM 2024**



NO	ITEM	UNIT PRICE (AED)			QUANTITY	TOTAL
		BEST PRICE <i>15 days before the event</i>	STANDARD PRICE <i>14 days or less from the build-up</i>	ONSITE ORDER <i>during build-up</i>		
Seamless Plasma Wall						
19	2 x 2 Seamless Plasma Wall	11,715.00	14,057.00	16,166.00		
20	3 x 3 Seamless Plasma Wall	22,050.00	26,460.00	30,429.00		
21	4 x 4 Seamless Plasma Wall	27,563.00	33,075.00	38,037.00		
LED Video Walls						
22	3.99mm LED Screen	2,150.00	2,580.00	2,967.00		
23	2.84mm LED Screen	1,340.00	1,680.00	1,932.00		
Computers						
24	Desktop PC P4	1,208.00	1,449.00	1,667.00		
25	Laptop	560.00	672.00	773.00		
26	Colour Laser Printer	1,075.00	1,290.00	1,484.00		
Sound/PA System						
27	Sound System for 15-30 Audience	2,867.00	3,440.00	3,956.00		
28	Sound System for 30-50 Audience	4,300.00	5,160.00	5,934.00		
29	Sound System for 50-75 Audience	5,733.00	6,880.00	7,912.00		
Additional Accessories for Sound System						
30	Wired Microphone	249.00	298.00	343.00		
31	Wireless Microphone	414.00	497.00	572.00		
32	Wireless Lapel Microphone	836.00	1,003.00	1,154.00		
33	Wireless Headset Microphone	1,241.00	1,489.00	1,713.00		
34	Podium Microphone	447.00	536.00	617.00		
Walkie Talkie						
35	Motorola Walkie Talkie (each)	331.00	397.00	457.00		
Video Splitters / Switchers						
36	Media Player	210.00	252.00	290.00		
37	Extron Video Switcher	414.00	497.00	572.00		
Gobo Projection						
38	Gobo Projection	5,017.00	6,020.00	6,923.00		
39	Moving Head Spot	1,103.00	1,323.00	1,522.00		
40	Fresnel 2K	490.00	588.00	677.00		
41	ETC Profile Light	560.00	672.00	773.00		
Translation System						
	Translation Equipment	As per requirement	As per requirement			
GRAND TOTAL (AED)						



TERMS & CONDITIONS

1. Prices are on rental basis for the duration of the event.
2. Invoice will be processed for all confirmed order within 3-5 working days.
3. All orders must be paid 15 days before the event; standard price will apply for any unpaid orders 14 days before the event.
4. All orders received after deadline date will be subject to availability of the item and standard price will apply.
5. Items will not be supplied unless payment is received.
6. Any damage or loss will be under the responsibility of the exhibitor.
7. **All prices, costs and charges are inclusive of 5% Value Added Tax.**

CANCELLATION POLICY

1. Cancellation of confirmed orders are not permitted.

ALL PAYMENTS MUST BE MADE PRIOR TO WORKS COMMENCING

Abu Dhabi National Exhibitions Company is (100%) Holding Company of ADNEC SERVICES LLC

Please complete and return the order form to the above email address. An invoice will be dispatched in return.
Orders will be Valid only with full remittance.

Name

Date

Signature



CREDIT CARD AUTHORIZATION FORM

To be returned by via e-mail to:

ADNEC Services LLC
P.O.Box 5546, Abu Dhabi - UAE

Contact: Finance Department
Tel: + 971 02 4063653
Email: finance.as@adnec.ae

I hereby give ADNEC SERVICES LLC my personal permission for the following credit card guarantee and pay for:

Name / Reference: _____

Amount to be Charged: _____

Type of Credit Card: Visa Card Master Card

My Credit Card No. is: _____

Issue Date: _____

Expiry Date: _____

Signature: _____ Date: _____

Name of Credit Card Holder as it Appears on the card: _____

Company name: _____

Full Address: _____

Tel/ Fax #: _____

Email Address: _____

Payment Details: _____



Tel +971 (0) 2 406 3666

P.O. Box 5546 Abu Dhabi



Fill & Return

adnecservices.oc@adnec.ae



Best Price

when you pay 15 days before
the event date



Standard Price

within 14 days or less
before the build-up days



Deadline

Submissions close 15 days prior to
the show, thereafter delivery cannot
be guaranteed and standard/on-site
price will apply

EXHIBITOR DETAILS:

Exhibiting Company Name: _____

Date: _____ Hall No. _____ Stand No. _____

** It is the exhibitor's responsibility to inform ADNEC Services of any changes to the stand number / service location.*

ORDER CONTACT DETAILS:

Full Name: _____

Job Title: _____

Company Name: _____

Company Address: _____

City: _____

Postal Code: _____

Country: _____

Contact No. _____

Email Address: _____

On-site Contact Name: _____

On-site Contact No. _____

** It is important to review TERMS AND CONDITIONS attached on this order form before submitting your order.*

INVOICE BILLING DETAILS:

Tax Registration No: _____

Same As Above

Preferred Invoice Currency USD

AED

Full Name: _____

Job Title: _____

Company Name: _____

Company Address: _____

City: _____

Postal Code: _____

Country: _____

Contact No. _____

Email Address: _____



ADNEC SERVICES LLC
OFFICIAL CONTRACTING
CARPET ORDER FORM 2024



ITEM	UNIT PRICE (AED)			QUANTITY	TOTAL
	BEST PRICE <i>14 days or less prior to the build-up days</i>	STANDARD PRICE <i>15 days prior to the event</i>	ONSITE PRICE <i>during build-up days</i>		
Exhibition Carpet	39.00	47.00	55.00		
Medium Quality Carpet	56.00	67.00	78.00		
Astroturf	67.00	80.00	92.00		
GRAND TOTAL (AED)					

Carpet Color Code Requirement:

Note: Carpet color is subject to availability. Color may vary in actual.

EXHIBITION CARPET

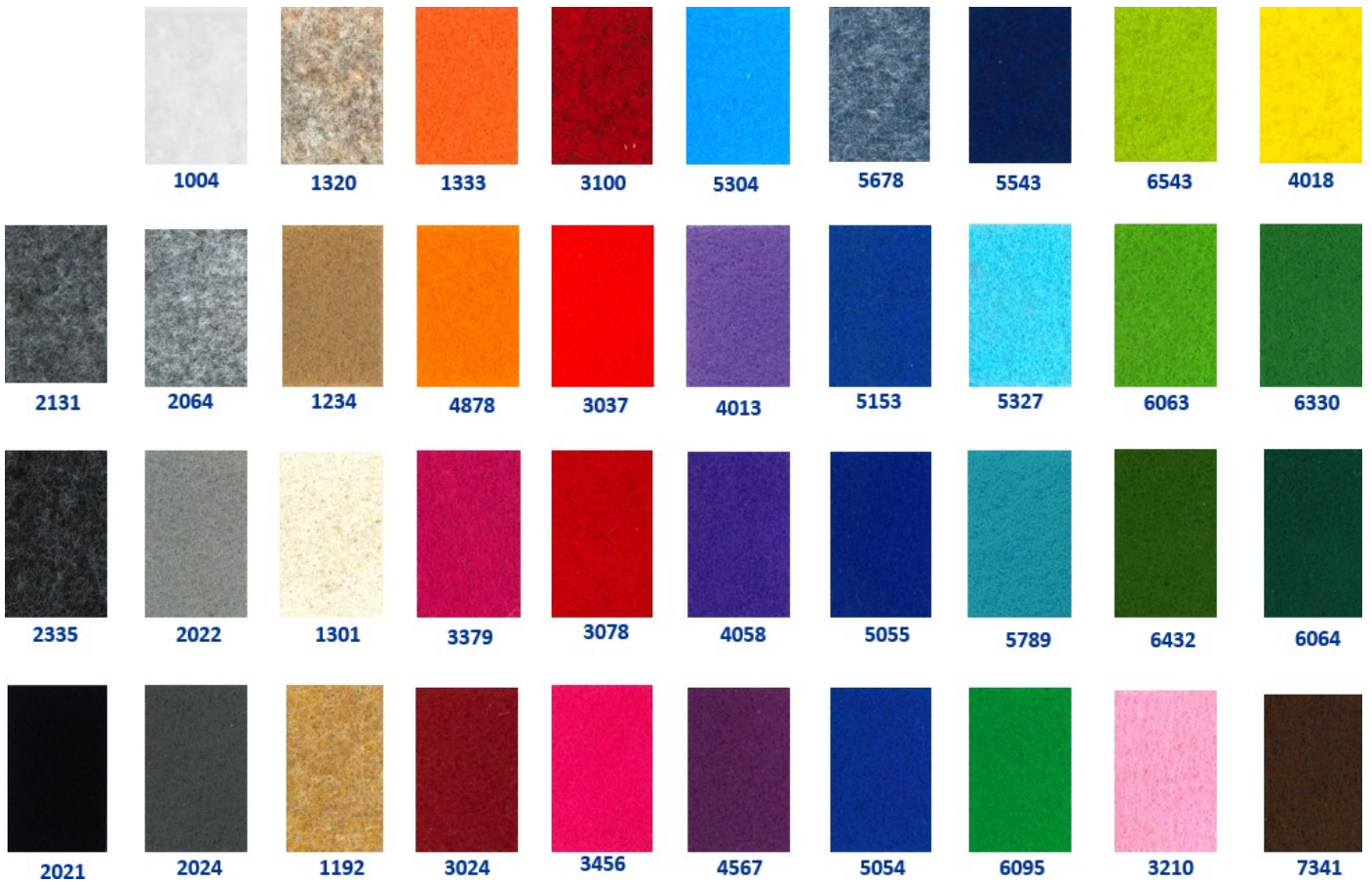

MEDIUM QUALITY CARPET

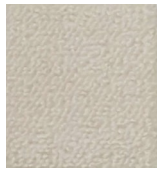

24



05



01



20



25



22



19



26



06



11



23



21

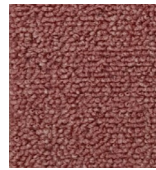

14



03



17

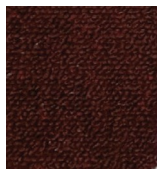

28



15



12

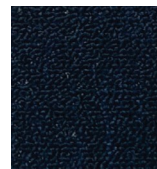

27

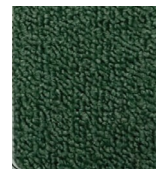

07

ASTROTURF CARPET



6 MM



TERMS & CONDITIONS

1. Carpet colors depending on the exhibitor's requirement and availability of the item.
2. Carpet Color Code Requirement is a must when filing this form.
3. Invoice will be processed for all confirmed order within 3-5 working days.
4. All orders must be paid 15 days before the event; standard price will apply for any unpaid orders 14 days before the event.
5. All orders received after deadline date will be subject to availability of the item and standard price will apply.
6. Items will not be supplied unless payment is received.
7. Any damage or loss will be under the responsibility of the exhibitor.
8. **All prices, costs and charges are inclusive of 5% Value Added Tax.**

CANCELLATION POLICY

1. Cancellation of confirmed orders are not permitted.

ALL PAYMENTS MUST BE MADE PRIOR TO WORKS COMMENCING

Abu Dhabi National Exhibitions Company is (100%) Holding Company of ADNEC SERVICES LLC

Please complete and return the order form to the above email address. An invoice will be dispatched in return.
Orders will be Valid only with full remittance.

Name

Date

Signature



CREDIT CARD AUTHORIZATION FORM

To be returned by via e-mail to:

ADNEC Services LLC
P.O.Box 5546, Abu Dhabi - UAE

Contact: Finance Department
Tel: + 971 02 4063813
Email: finance.as@adnec.ae

I hereby give ADNEC SERVICES LLC my personal permission for the following credit card guarantee and pay for:

Name /Reference: _____

Amount to be Charged: _____

Type of Credit Card: Visa Card Master Card

My Credit Card No. is: _____

Issue Date: _____

Expiry Date: _____

Signature: _____ Date: _____

Name of Credit Card Holder as it Appears on the card: _____

Company name: _____

Full Address: _____

Tel/ Fax # : _____

Email Address: _____

Payment Details: _____



Tel +971 (0) 2 406 3666

P.O. Box 5546 Abu Dhabi



EXHIBITOR DETAILS:

Exhibiting Company Name: _____

Date: _____ Hall No. _____ Stand No. _____

** It is the exhibitor's responsibility to inform ADNEC Services of any changes to the stand number / service location.*

Fill & Return
adnecservices.oc@adnec.ae



ORDER CONTACT DETAILS:

Full Name: _____

Job Title: _____

Company Name: _____

Company Address: _____

City: _____

Postal Code: _____

Country: _____

Contact No. _____

Email Address: _____

On-site Contact Name: _____

On-site Contact No. _____

** It is important to review TERMS AND CONDITIONS attached on this order form before submitting your order.*

Best Price
when you pay 15 days before
the event date



INVOICE BILLING DETAILS:

Standard Price
within 14 days or less
before the build-up days

Tax Registration No: _____

Same As Above

Preferred Invoice Currency USD AED

Full Name: _____

Job Title: _____

Company Name: _____

Company Address: _____

City: _____

Postal Code: _____

Country: _____

Contact No. _____

Email Address: _____



Deadline
Submissions close 15 days prior to
the show, thereafter delivery cannot
be guaranteed and standard/on-site
price will apply



**ADNEC SERVICES LLC
OFFICIAL CONTRACTING
FURNITURE ORDER FORM 2024**



CODE	ITEMS	DESCRIPTION		UNIT PRICE (AED)			QTY	TOTAL
		COLOR/KIND/SIZE		BEST PRICE <i>15 days prior to the event</i>	STANDARD PRICE <i>14 days or less prior to the build-up days</i>	ONSITE PRICE <i>during build-up days</i>		
<u>Chairs and Bar Stool</u>								
C-1	White stackable chair	White, Chrome Leg	Single	144.00	172.00	197.80		
C-2	Office Chair 1	White, Synthetic, Plastic & Chrome Leg	Single	204.00	245.00	281.75		
C-3	Office Chair 2	White Leather, Back Rest Chrome Leg	Single	182.00	219.00	251.85		
C-4	Bar Stool 1	White Leather, Steel Tubing, Back Rest, Chrome Leg	Single	144.00	172.00	197.80		
C-5	Bar Stool 2	White Leather, Steel Tubing, Back Rest, Chrome Leg	Single	144.00	172.00	197.80		
C-6	Bar Stool 3	White Plastic, Steel Tubing, Back Rest, Chrome Leg	Single	144.00	172.00	197.80		
C-7	Bar Stool 4	White Leather, Chrome Leg	Single	144.00	172.00	197.80		
<u>Tub Chairs</u>								
TC-1	Tub Chair 1	White Leather, Chrome Leg, (wheels)	Single	287.00	344.00	395.60		
TC-2	Tub Chair 2	White Leather, Chrome Leg	Single	287.00	344.00	395.60		
<u>Sofas</u>								
S1	Sofa Single 1	White Leather, Chrome Leg	Single	408.00	490.00	563.50		
S-2	Sofa Single 2	White Leather, Chrome Leg	Single	408.00	490.00	563.50		
S-3	Sofa Single 3	White Leather, Chrome Leg	Single	304.00	364.00	418.60		
S-4	Sofa Double	White Leather, Chrome Leg	Double	568.00	682.00	784.30		
<u>Tables</u>								
T-1	Round Table	Wooden Top, Adjustable Height, Chrome Leg	800mm dia, 80cmH	166.00	199.00	228.85		
T-2	Glass Round Table 1	Tempered Glass Top, Chrome Leg	800mm dia, 80cmH	304.00	364.00	418.60		
T-3	Wooden Bar Table	Wooden Top, Wooden Leg, Tri-pod	800mm dia, 120cmH	204.00	245.00	281.75		
T-4	Square Table	White, Laminated, Chrome Leg	70cmWx70cmLx80cmH	166.00	199.00	228.85		
T-5	Square Coffee Table	Wooden Top, Laminated, Wooden Leg	70cmWx70cmLx80cmH	122.00	146.00	167.90		
T-6	Square Glass Coffee Table	Tempered Glass Top, Chrome Leg	50cmWx50cmLx50cmH	166.00	199.00	228.85		
T-7	Square Glass Coffee Table	Tempered Glass Top, Chrome Leg	50cmWx50cmLx50cmH	243.00	292.00	335.80		
T-8	Rectangular Coffee Table	Tempered Glass Top, Chrome Leg	50cmWx70cmLx50cmH	265.00	318.00	365.70		
T-9	Long Table	Wooden, Laminated, Steel Leg	120cmLx60cmWx70cmH	221.00	265.00	304.75		



**ADNEC SERVICES LLC
OFFICIAL CONTRACTING
FURNITURE ORDER FORM 2024**



CODE	ITEMS	DESCRIPTION		UNIT PRICE (AED)			QTY	TOTAL
		COLOR/KIND/SIZE		BEST PRICE <i>15 days prior to the event</i>	STANDARD PRICE <i>14 days or less prior to the build-up days</i>	ONSITE PRICE <i>during build-up days</i>		
<u>Display & Accessories</u>								
D-1	Safe Box	White or Black, Steel with combination for lock		1,423.00	1,707.00	1,963.05		
D-2	OCTANORM Cube -Large	White, Aluminum, MDF	500x500x 1000	204.00	245.00	281.75		
D-3	OCTANORM Cube -Medium	White, Aluminum, MDF	500x500x500	182.00	219.00	251.85		
D-4	OCTANORM Cube -Small	White, Aluminum, MDF	500x500x300	166.00	199.00	228.85		
D-5	Lockable Counter	White-Wood & Aluminum	1018x540x1040	265.00	318.00	365.70		
D-6	Plain Counter	White-Wood & Aluminum	860x500x1000	204.00	245.00	281.75		
D-7	Counter Showcase	Glass & Aluminum	1000x500x900	491.00	589.00	677.35		
D-8	Tall Showcase 1	Glass & Aluminum	35cmWx 100cmLx 180cmH	811.00	973.00	1,118.95		
D-9	Tall Showcase 2	Glass & Aluminum	50cmWx100cmLx 200cmH	811.00	973.00	1,118.95		
D-10	Tower Showcase	Glass & Aluminum	50cmW x180cmH x 50cmD	612.00	735.00	845.25		
D-11	Folding Brochure Rack	Tempered Glass, Chrome frame		408.00	490.00	563.50		
D-12	Waste Bin	Plastic or Perforated Mesh		47.00	56.00	64.40		
D-13	Textile Rack	Steel & Chrome Structure		265.00	318.00	365.70		
D-14	Display Shelving (4-Tier)	Chrome		403.00	483.00	555.45		
D-15	Barrier	Red or Blue, Chrome Leg		204.00	245.00	281.75		
D-16	Refrigerator (small)	Bar Fridge		1,015.00	1,218.00	1,400.70		
All prices net on hire				GRAND TOTAL:				

			
<p>C-1 <u>White Stackable Chair</u> White, Chrome Leg 80cmH x 46cmW x 40cmD</p>	<p>C-2 <u>Office Chair 1</u> White, Synthetic, PVC & Chrome Leg 58cmW x 90cmH</p>	<p>C-3 <u>Office Chair 2</u> White Leather, Back Rest, Chrome Leg 55cmW x 95 - 110cmH</p>	<p>C-4 <u>Bar Stool 1</u> White Leather, Steel Tubing, Back Rest, Chrome Leg 44cmW x 44cmD x adjustable H</p>
			
<p>C-5 <u>Bar Stool 2</u> White Leather, Steel Tubing, Back Rest, Chrome Leg 44cmW x 44cmD x adjustable H</p>	<p>C-6 <u>Bar Stool 3</u> White PVC, Back Rest, Chrome Leg 44cmW x 44cmD x adjustable H</p>	<p>C-7 <u>Bar Stool 4</u> White Leather, Chrome Leg 44cmW x 44cmD x adjustable H</p>	<p>TC-1 <u>Tub Chair 1</u> White Leather, Chrome Leg (wheels) 42cmW x 83cmW x 41cmD</p>
			
<p>TC-2 <u>Tub Chair 2</u> White Leather, Chrome Leg 42cmW x 83cmW x 41cmD</p>	<p>S-1 <u>Sofa Single 1</u> White Leather, Chrome Leg 85cmW x 80cmH</p>	<p>S-2 <u>Sofa Single 2</u> White Leather, Chrome Leg 75cmW x 75cmH</p>	
			
<p>S-3 <u>Sofa Single 3</u> White Leather, Wooden Leg 78cmW x 76cmH</p>			
			
<p>S-4 <u>Sofa Double</u> White Leather, Chrome Leg 140cmW x 80cmH</p>	<p>T-1 <u>Round Table</u> Wooden Top, Adjustable Height, Chrome Leg 80cm diameter, 80cmH</p>	<p>T-2 <u>Glass Round Table</u> Tempered Glass Top, Chrome leg 80cm diameter, 80cmH</p>	<p>T-3 <u>Wooden Bar Table</u> Wooden Top, Wooden Leg, 80cm diameter, 120cmH</p>



**ADNEC SERVICES LLC
OFFICIAL CONTRACTING
FURNITURE ORDER FORM 2024**



T-4

Square Table
White, Laminated, Chrome Leg,
70cmW x 80cmH x 70cmD



T-5

Square Coffee Table
Wooden Top, Laminated,
Wooden Leg
50cmW x 50cmH x 50cmD



T-6

Square Glass Coffee Table 1
Tempered Glass Top, Chrome Leg
50cmW x 50cmH x 50cmD



T-7

Square Glass Coffee Table 2
Tempered Glass Top, Chrome Leg
50cmW x 50cmH x 50cmD



T-8 Rectangular Coffee Table
Tempered Glass Top, Chrome Leg
50cmW x 50cmH x 70cmD



T-9 Long table
Wooden, Laminated, Wooden Leg
120cmL x 60cmW x 70cmH



D-1 Safe Box
White or Black,
Steel with digital lock



D-2 OCTANORM Cube - Large
White, Aluminum, MDF
500x500x 1000



D-3 OCTANORM Cube - Medium
White, Aluminum, MDF
500x500x 820



D-4 OCTANORM Cube - Small
White, Aluminum, MDF
500x500x 530



D-5 Lockable Counter
White-Wood & Aluminum
100cmW x 82cmH x 50cmD



D-6 Plain Counter
White-Wood & Aluminum
100cmW x 82cmH x 50cmD



D-7 Counter Showcase
Glass & Aluminum
100cmW x 90cmH x 45cmD



D-8 Tall Showcase 1
Glass & Aluminum
35cmWx 100cmLx 180cmH



D-9 Tall Showcase 2
Glass & Aluminum
50cmWx 100cmLx 200cmH



D-10 Tower Showcase
Glass & Aluminum -
50cmW x 180cmH x 50cmD



D-11 Folding Brochure Rack
Tempered Glass,
chrome frame



D-12 Waste Bin
25cmW x 35cmH



D-13 Textile Rack Steel & Chrome FS
120cmW x 120-140cmH



D-14 Display Shelving (4-Tier)
Chrome
100W x 45D x 200H cm







**ADNEC SERVICES LLC
OFFICIAL CONTRACTING
FURNITURE ORDER FORM 2024**



TERMS & CONDITIONS

1. Prices are on rental basis for the duration of the event.
2. Invoice will be processed for all confirmed order within 3-5 working days.
3. All orders must be paid 15 days before the event; standard price will apply for any unpaid orders 14 days before the event.
4. All orders received after deadline date will be subject to availability of the item and standard price will apply.
5. Items will not be supplied unless payment is received.
6. Any damage or loss will be under the responsibility of the exhibitor.
7. **All prices, costs and charges are inclusive of 5% Value Added Tax.**

CANCELLATION POLICY

1. Cancellation of confirmed orders are not permitted.

ALL PAYMENTS MUST BE MADE PRIOR TO WORKS COMMENCING

Abu Dhabi National Exhibitions Company is (100%) Holding Company of ADNEC SERVICES LLC

Please complete and return the order form to the above email address. An invoice will be dispatched in return.
Orders will be Valid only with full remittance.

Name

Date

Signature



CREDIT CARD AUTHORIZATION FORM

To be returned by via e-mail to:

ADNEC Services LLC
P.O.Box 5546, Abu Dhabi - UAE

Contact: Finance Department
Tel: + 971 02 4063653
Email: finance.as@adnec.ae

I hereby give ADNEC SERVICES LLC my personal permission for the following credit card guarantee and pay for:

Name /Reference: _____

Amount to be Charged: _____

Type of Credit Card: Visa Card Master Card

My Credit Card No. is: _____

Issue Date: _____

Expiry Date: _____

Signature: _____ Date: _____

Name of Credit Card Holder as it Appears on the card: _____

Company name: _____

Full Address: _____

Tel/ Fax # : _____

Email Address: _____

Payment Details: _____



Tel +971 (0) 2 406 3666

P.O. Box 5546 Abu Dhabi

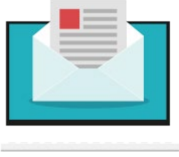

Fill & Return

adnecservices.oc@adnec.ae



Best Price

when you pay 15 days
before the event



Standard Price

within 14 days or less
before the build-up days



Deadline

Submissions close 15 days prior to
the show, thereafter delivery cannot
be guaranteed and standard/on-site
price will apply

EXHIBITOR DETAILS:

Exhibiting Company Name: _____

Date: _____ Hall No. _____ Stand No. _____

** It is the exhibitor's responsibility to inform ADNEC Services of any changes to the stand number / service location.*

ORDER CONTACT DETAILS:

Full Name: _____

Job Title: _____

Company Name: _____

Company Address: _____

City: _____

Postal Code: _____

Country: _____

Contact No. _____

Email Address: _____

On-site Contact Name: _____

On-site Contact No. _____

** It is important to review TERMS AND CONDITIONS attached on this order form before submitting your order.*

INVOICE BILLING DETAILS:

Tax Registration No: _____

Same As Above

Preferred Invoice Currency USD

AED

Full Name: _____

Job Title: _____

Company Name: _____

Company Address: _____

City: _____

Postal Code: _____

Country: _____

Contact No. _____

Email Address: _____

PLEASE NOTE:

- 1- Lights and sockets are located on the beams and poles.
- 2- Sockets provided on the shell scheme stands can only provide power up to 600watts. Anything above 600watts power will be chargeable.
- 3- The location of the distribution boards will be decided by ADNEC Services.

CODE	DESCRIPTION	UNIT PRICE (AED)			QUANTITY	TOTAL
		BEST PRICE <i>15 days prior to the event</i>	STANDARD PRICE <i>14 days or less prior to the build-up days</i>	ONSITE PRICE <i>during build-up days</i>		
E-1	3-Pin Electrical Socket (British Standard) SINGLE	309.00	371.00	427.00		
E-2	3-Pin Electrical Socket (British Standard) DOUBLE	552.00	662.00	762.00		
E-3	Multi Pin Plug Adaptor	28.00	34.00	40.00		
E-4	Spotlight on Track	276.00	331.00	381.00		
E-5	Arm Spotlight	309.00	371.00	427.00		
E-6	4 way Extension Bar	105.00	126.00	145.00		
GRAND TOTAL (AED)						



E-1

3-PIN ELECTRICAL SOCKET-SINGLE



E-2

3-PIN ELECTRICAL SOCKET-DOUBLE



E-3

MULTI PIN PLUG ADAPTOR



E-4

SPOT LIGHT ON TRACK



E-5

ARM SPOTLIGHT



E-6

4 WAY EXTENSION



**ADNEC SERVICES LLC
OFFICIAL CONTRACTING
SHELL SCHEME ELECTRICAL
ORDER FORM 2024**



Please complete the following grid plan to indicate the preferred location of your power / utility supply

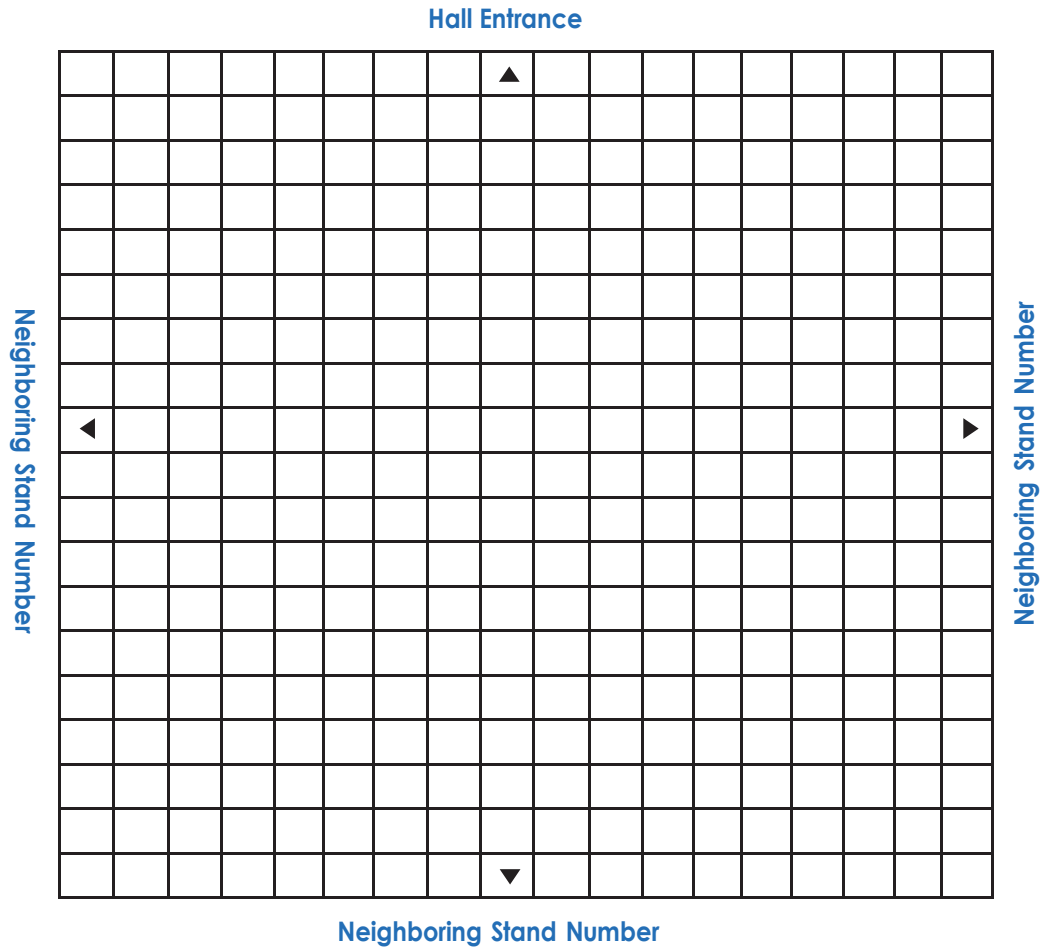

PLEASE SPECIFY THE FOLLOWING:

Position of the ordered utilities		
Stand on left side		
Stand on right side		
Stand at rear		



**ADNEC SERVICES LLC
OFFICIAL CONTRACTING
SHELL SCHEME ELECTRICAL
ORDER FORM 2024**



TERMS & CONDITIONS

1. Prices are on rental basis for the duration of the event.
2. Invoice will be processed for all confirmed order within 3-5 working days.
3. Completed Grid Plan is required.
4. All orders must be paid 15 days before the event; standard price will apply for any unpaid orders 14 days before the event.
5. All orders received after deadline date will be subject to availability of the item and standard price will apply.
6. Items will not be supplied unless payment is received.
7. Any damage or loss will be under the responsibility of the exhibitor.
8. **All prices, costs and charges are inclusive of 5% Value Added Tax.**

CANCELLATION POLICY

1. Cancellation of confirmed orders are not permitted.

ALL PAYMENTS MUST BE MADE PRIOR TO WORKS COMMENCING

Abu Dhabi National Exhibitions Company is (100%) Holding Company of ADNEC SERVICES LLC

Please complete and return the order form to the above email address. An invoice will be dispatched in return.
Orders will be Valid only with full remittance.

Name

Date

Signature



ADNEC SERVICES LLC
OFFICIAL CONTRACTING
SHELL SCHEME ELECTRICAL
ORDER FORM 2024



CREDIT CARD AUTHORIZATION FORM

To be returned by via e-mail to:

ADNEC Services LLC
P.O.Box 5546, Abu Dhabi - UAE

Contact: Finance Department
Tel: + 971 02 4063653
Email: finance.as@adnec.ae

I hereby give ADNEC SERVICES LLC my personal permission for the following credit card guarantee and pay for:

Name /Reference: _____

Amount to be Charged: _____

Type of Credit Card: Visa Card Master Card

My Credit Card No. is: _____

Issue Date: _____

Expiry Date: _____

Signature: _____ Date: _____

Name of Credit Card Holder as it Appears on the card: _____

Company name: _____

Full Address: _____

Tel/ Fax # : _____

Email Address: _____

Payment Details: _____



ADNEC SERVICES LLC OFFICIAL CONTRACTING SHELL SCHEME STAND FITTING ORDER FORM 2024



Tel +971 (0) 2 406 3666

P.O. Box 5546 Abu Dhabi



Fill & Return

adnecservices.oc@adnec.ae



Best Price

when you pay 15 days before
the event date



Standard Price

within 14 days or less
before the build-up days



Deadline

Submissions close 15 days prior
to the show, thereafter delivery
cannot be guaranteed and
standard/on-site price will apply

EXHIBITOR DETAILS:

Exhibiting Company Name: _____

Date: _____ Hall No. _____ Stand No. _____

** It is the exhibitor's responsibility to inform ADNEC Services of any changes to the stand number / service location.*

ORDER CONTACT DETAILS:

Full Name: _____

Job Title: _____

Company Name: _____

Company Address: _____

City: _____

Postal Code: _____

Country: _____

Contact No. _____

Email Address: _____

On-site Contact Name: _____

On-site Contact No. _____

** It is important to review TERMS AND CONDITIONS attached on this order form before submitting your order.*

INVOICE BILLING DETAILS:

Tax Registration No: _____

Same As Above

Preferred Invoice Currency USD

AED

Full Name: _____

Job Title: _____

Company Name: _____

Company Address: _____

City: _____

Postal Code: _____

Country: _____

Contact No. _____

Email Address: _____

CODE	ITEMS	DESCRIPTION	UNIT PRICE (AED)			QUANTITY	TOTAL
			BEST PRICE <i>15 days prior to the event</i>	STANDARD PRICE <i>14 days or less prior to the build-up days</i>	ONSITE PRICE <i>during build-up days</i>		
SF-1	Flat Shelf for shell scheme	Wooden Laminated MDF 100cmW x 30cmD	83.00	100.00	115.00		
SF-2	Flat Shelf for wooden wall	Wooden painted	166.00	199.00	229.00		
SF-3	Sloped Shelf for shell scheme	Wooden Laminated MDF 100cmW x 30cmD	105.00	126.00	145.00		
SF-4	Folding Door for Shell Scheme	96cmW x 200cmH	282.00	338.00	389.00		
SF-5	Octanorm Panel	100cmW x 250cmH	204.00	245.00	282.00		
SF-6	Grid Panel	Steel - 2x1	552.00	662.00	762.00		
SF-7A	Grid Panel Hook (per piece)	Short	21.00	25.00	29.00		
SF-7B	Grid Panel Hook (per piece)	Long	41.00	49.00	57.00		
SF-8A	S-Hooks (per piece)	Short	21.00	25.00	29.00		
SF-8B	S-Hooks (per piece)	Long	41.00	49.00	57.00		
SF-9	Coat Hooks		21.00	25.00	29.00		
GRAND TOTAL (AED):							



SD-1 FLAT SHELF

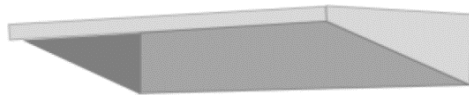

SF-2 FLAT SHELF (FOR WOODEN WALL)



SF-3 SLOPED SHELF



SF-4 FOLDING DOOR



SF-5 OCTANORM PANEL

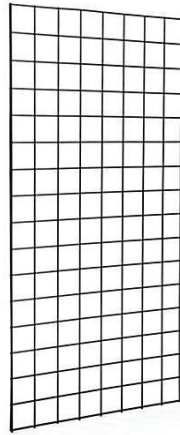

SF- 6 GRID PANEL



SF-7A GRID PANEL HOOK (SHORT)



SF-7B GRID PANEL HOOK (LONG)



SF-8A S-HOOKS (SHORT)



SF-8A S-HOOKS (LONG)

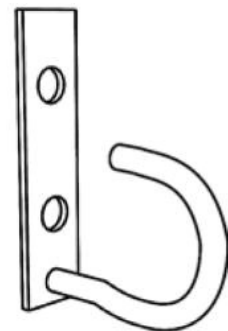

SF-9 COAT HOOKS



**ADNEC SERVICES LLC
OFFICIAL CONTRACTING
SHELL SCHEME STAND FITTING
ORDER FORM 2024**



*Any requirement not mentioned above please contact us and we will try all what we can do to accommodate your request

Please complete the following grid plan to indicate the preferred location of your stand fitting order

Stand Orientation Grid

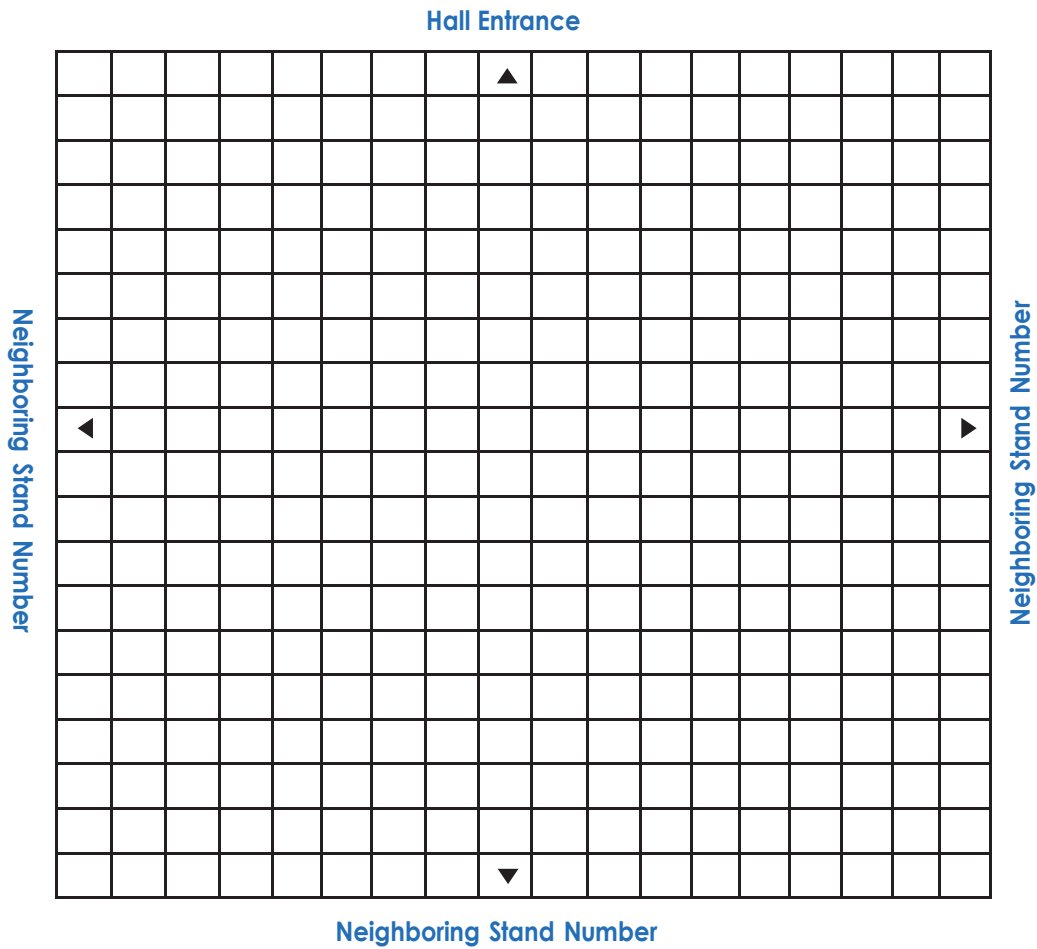

PLEASE SPECIFY THE FOLLOWING:

Position of the ordered utilities		
Stand on left side		
Stand on right side		
Stand at rear		



**ADNEC SERVICES LLC
OFFICIAL CONTRACTING
SHELL SCHEME STAND FITTING
ORDER FORM 2024**



TERMS & CONDITIONS

1. Prices are on rental basis for the duration of the event.
2. Invoice will be processed for all confirmed order within 3-5 working days.
3. All orders received after deadline date will be subject to availability of the item and standard price will apply.
4. All orders must be paid 15 days before the event; standard price will apply for any unpaid orders 14 days before the event.
4. Items will not be supplied unless payment is received.
5. Any damage or loss will be under the responsibility of the exhibitor.
6. **All prices, costs and charges are inclusive of 5% Value Added Tax.**

CANCELLATION POLICY

1. Cancellation of confirmed orders are not permitted.

ALL PAYMENTS MUST BE MADE PRIOR TO WORKS COMMENCING

Abu Dhabi National Exhibitions Company is (100%) Holding Company of ADNEC SERVICES LLC

Please complete and return the order form to the above email address. An invoice will be dispatched in return.
Orders will be Valid only with full remittance.

Name

Date

Signature



ADNEC SERVICES LLC
OFFICIAL CONTRACTING
SHELL SCHEME STAND FITTING
ORDER FORM 2024



CREDIT CARD AUTHORIZATION FORM

To be returned by via e-mail to:

ADNEC Services LLC
P.O.Box 5546, Abu Dhabi - UAE

Contact: Finance Department
Tel: + 971 02 4063653
Email: finance.as@adnec.ae

I hereby give ADNEC SERVICES LLC my personal permission for the following credit card guarantee and pay for:

Name /Reference: _____

Amount to be Charged: _____

Type of Credit Card: Visa Card Master Card

My Credit Card No. is: _____

Issue Date: _____

Expiry Date: _____

Signature: _____ Date: _____

Name of Credit Card Holder as it Appears on the card: _____

Company name: _____

Full Address: _____

Tel/ Fax # : _____

Email Address: _____

Payment Details: _____



Tel +971 (0) 2 406 3666

P.O. Box 5546 Abu Dhabi



Fill & Return

adnecservices.oc@adnec.ae



Best Price

when you pay 15 days before
the event date



Standard Price

within 14 days or less
before the build-up days



Deadline

Submissions close 15 days prior to
the show, thereafter delivery cannot
be guaranteed and standard/on-site
price will apply

EXHIBITOR DETAILS:

Exhibiting Company Name: _____

Date: _____ Hall No. _____ Stand No. _____

** It is the exhibitor's responsibility to inform ADNEC Services of any changes to the stand number / service location.*

ORDER CONTACT DETAILS:

Full Name: _____

Job Title: _____

Company Name: _____

Company Address: _____

City: _____

Postal Code: _____

Country: _____

Contact No. _____

Email Address: _____

On-site Contact Name: _____

On-site Contact No. _____

** It is important to review TERMS AND CONDITIONS attached on this order form before submitting your order.*

INVOICE BILLING DETAILS:

Tax Registration No: _____

Same As Above

Preferred Invoice Currency USD

AED

Full Name: _____

Job Title: _____

Company Name: _____

Company Address: _____

City: _____

Postal Code: _____

Country: _____

Contact No. _____

Email Address: _____



ADNEC SERVICES LLC
OFFICIAL CONTRACTING
SHELL SCHEME GRAPHICS
ORDER FORM 2024



NOS	ITEM	DESCRIPTION	UNIT PRICE (AED)			QTY	TOTAL
			BEST PRICE <i>15 days prior to the event</i>	STANDARD PRICE <i>14 days or less prior to the build-up days</i>	ONSITE PRICE <i>during build-up days</i>		
1	Fascia logo	21cmH x 200cmW	304.00 per logo	364.00 per logo	419.00		
2	Seamless Fascia	35cmH x stand width <i>rates x Lm</i>	204.00 per Lm	245.00 per Lm	282.00		
3	Seamless Wall Graphics	250cmH x stand width <i>rates x nos. of panel</i>	761.00 per panel	913.00 per panel	1,050.00		
4	Panel Graphics (Sticker)	236xmH x 96cmW	761.00 per panel	913.00 per panel	1,050.00		
5	Counter Sticker Front Branding	87cmH x 97cmW	204.00	245.00	282.00		
6	Counter Foam Full Branding	Front: 98cmH x 104cmW Side: 98cmH x 54cmW	609.00	731.00	841.00		
7	Foam Board Poster/ Sticker	Min. 0.50 sqm	304.00 per sqm	364.00 per sqm	419.00		

GRAND TOTAL (AED)

TERMS & CONDITIONS

1. Upon order confirmation, **Ready to print artwork** must be submitted to email: adnecservices.oc@adnec.ae not later than 3 weeks prior to the show.
2. Invoice will be processed for all confirmed order within 3-5 working days.
3. Orders after deadline date is subject to Adnec Services approval
4. All orders must be paid 15 days before the event; standard price will apply for any unpaid orders 14 days before the event.
5. Items will not be supplied unless payment is received.
6. Any damage or loss will be under the responsibility of the exhibitor.
7. All prices costs and charges are inclusive of 5% Value Added Tax.

CANCELLATION POLICY

1. Cancellation of confirmed orders are not permitted.

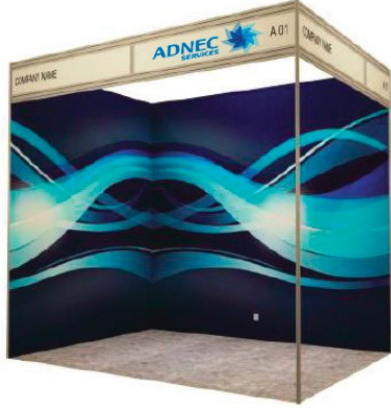

LOGO ON FASCIA



SEAMLESS FASCIA



SEAMLESS WALL GRAPHICS

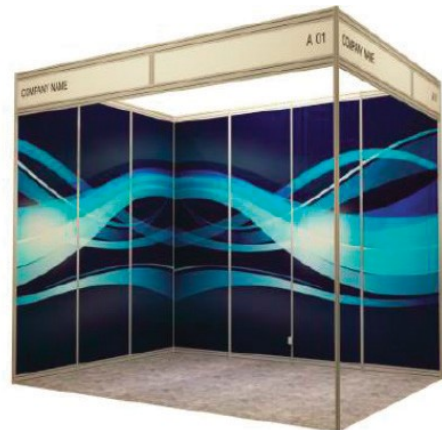

PANEL GRAPHICS



COUNTER STICKER FRONT BRANDING

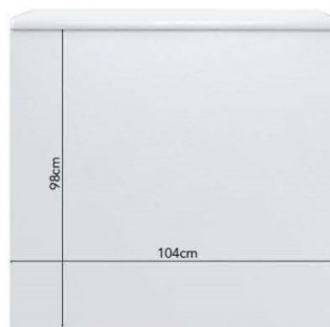

With Full Foamboard Graphics

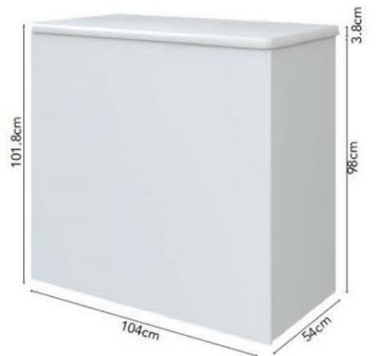

COUNTER FOAM FULL BRANDING



**ADNEC SERVICES LLC
OFFICIAL CONTRACTING
SHELL SCHEME GRAPHICS
ORDER FORM 2024**



ALL PAYMENTS MUST BE MADE PRIOR TO WORKS COMMENCING

Abu Dhabi National Exhibitions Company is (100%) Holding Company of ADNEC SERVICES LLC

Please complete and return the order form to the above email address. An invoice will be dispatched in return.
Orders will be Valid only with full remittance.

Name

Date

Signature



CREDIT CARD AUTHORIZATION FORM

To be returned by via e-mail to:

ADNEC Services LLC
P.O.Box 5546, Abu Dhabi - UAE

Contact: Finance Department
Tel: + 971 02 4063653
Email: finance.as@adnec.ae

I hereby give ADNEC SERVICES LLC my personal permission for the following credit card guarantee and pay for:

Name /Reference: _____

Amount to be Charged: _____

Type of Credit Card: Visa Card Master Card

My Credit Card No. is: _____

Issue Date: _____

Expiry Date: _____

Signature: _____ Date: _____

Name of Credit Card Holder as it Appears on the card: _____

Company name: _____

Full Address: _____

Tel/ Fax # : _____

Email Address: _____

Payment Details: _____



Tel +971 (0) 2 406 3666 Fax +971 (0) 2 449 9770 P.O. Box 5546 Abu Dhabi



Fill & Return
adnecservices@adnec.ae



Best Price
when you pay 15 days
before the event



Standard Price
within 14 days or less prior
to the build-up days



Deadline
Submissions close 15 days prior
to the show, thereafter delivery
cannot be guaranteed and
standard/on-site price will apply

EXHIBITOR DETAILS:

Exhibiting Company Name: _____

Date: _____ Hall No. _____ Stand No. _____
Stand Name: _____

** It is the exhibitor's responsibility to inform ADNEC Services of any changes to the stand number / service location.*

ORDER CONTACT DETAILS:

Full Name: _____

Job Title: _____
Company Name: _____
Company Address: _____
City: _____
Postal Code: _____
Country: _____
Contact No. _____
Email Address: _____
On-site Contact Name: _____
On-site Contact No. _____

** It is important to review TERMS AND CONDITIONS attached on this order form before submitting your order.*

INVOICE BILLING DETAILS:

Tax Registration No: _____
Same As Above
Preferred Invoice Currency: USD AED
Full Name: _____

Job Title: _____
Company Name: _____
Company Address: _____
City: _____
Postal Code: _____
Country: _____
Contact No. _____
Email Address: _____



**ADNEC SERVICES LLC
OFFICIAL CONTRACTING
SPACE ONLY ELECTRICAL
ORDER FORM 2024**



All Electrical supplies installed above 16 Amps Single-phase are fitted with a 16 Amps Single-Phase power connection for build-up period only.

DESCRIPTION	UNIT PRICE (AED)			QUANTITY	TOTAL AMOUNT
	BEST PRICE <i>15 days prior to the event</i>	STANDARD PRICE <i>14 days or less prior to the build-up days</i>	ON-SITE PRICE <i>during build-up days</i>		
16 Amp. Single-Phase	1,213.00	1,323.00	1,985.00		
32 Amp. Single-Phase	2,426.00	2,867.00	4,300.00		
16 Amp. Three-Phase	3,650.00	4,190.00	6,285.00		
32 Amp. Three-Phase	6,064.00	6,836.00	10,255.00		
63 Amp. Three-Phase	10,364.00	11,246.00	16,870.00		
100 Amp. Three-Phase	17,089.00	20,507.00	30,761.00		
125 Amp. Three-Phase	POA	POA	POA		
24 Hrs Supply	+20%	+20%	+30%		
Build-up Power	464.00	556.00	835.00		
Ceiling Cable + 16 Amp. Single-Phase	2,602.00	2,990.00	4,485.00		
Ceiling Cable + 16 Amp. Three-Phase	5,965.00	6,968.00	10,455.00		
Ceiling Cable + 32 Amp. Single-Phase	4,164.00	4,951.00	7,430.00		
Ceiling Cable + 32 Amp. Three-Phase	8,379.00	9,551.00	14,330.00		
Single Phase Distribution Board	3,308.00	3,969.00	2,980.00		
Three Phase Distribution Board	4,851.00	5,822.00	4,370.00		
4-Way 13A Extension Bar	441.00	585.00	880.00		
16 Amps CEE form plug (Supply only)	177.00	221.00	335.00		
16 Amps CEE form socket (Supply only)	177.00	221.00	335.00		
Water and Waste	8,016.00	8,379.00	12,570.00		
Note: 50% additional surcharge for on-site orders and changes.					
GRAND TOTAL (AED) :					

TERMS & CONDITIONS

- The Technical Floor Plan should show exact locations of all services required.
- Form should be return to ADNEC Services during Early Bird period, nor Standard Price will apply.
- The Nominal Electrical Supply is 230v/400v 50hz
- ADNEC Services holds the exclusive right to utility services within ADNEC
- All utility orders must be paid in full at the time of ordering.
- Successful delivery of your order is dependent on the correct stand number and name of exhibiting company being provided. Please ensure that any changes to the stand number or exhibiting company name are communicated to ADNEC Services by e-mailing adnecservices@adnec.ae
- Stand Contractors are responsible for switching on their mains power 1 hour before and switching off 1 hour after the show closing times during the show days.
- Prices quoted are for supplies within the Exhibition and Event facilities.
- All External Supplies and supplies requiring special generation or transformation will be subject to quotation and prices upon application.
- Distribution Board are on rental basis only for the duration of the event.
- All orders must be paid 15 days before the event; standard price will apply for any unpaid orders 14 days before the event.
- All orders received after deadline date will be subject to availability of the item and standard price will apply.
- Items will not be supplied unless payment is received.
- Invoice will be processed for all confirmed order within 3-5 working days.
- Any damage or loss will be under the responsibility of the exhibitor.
- **All prices, costs and charges are inclusive of 5% Value Added Tax.**



CANCELLATION POLICY

1. Cancellation of confirmed orders will incur a **30% cancellation charge** from the amount of the invoice.

Please Note:

- All orders for utilities must follow the required guidelines and be submitted with a clear and precise grid plan at the time of ordering
- Any changes required due to incorrect grid plan will be subject to an additional charge.

Stand Orientation Grid

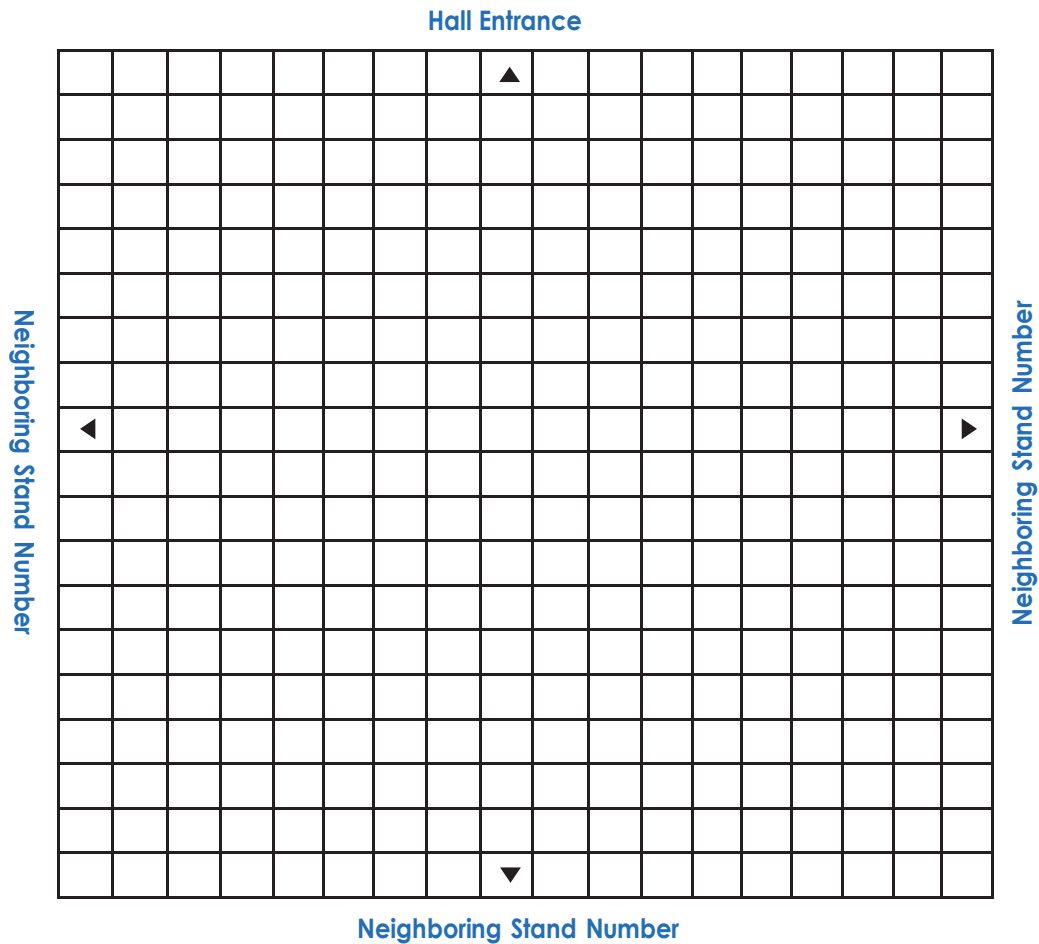

PLEASE SPECIFY THE FOLLOWING:

Position of the ordered utilities		
Stand on left side		
Stand on right side		
Stand at rear		



**ADNEC SERVICES LLC
OFFICIAL CONTRACTING
SPACE ONLY ELECTRICAL
ORDER FORM 2024**



ALL PAYMENTS MUST BE MADE PRIOR TO WORKS COMMENCING

Abu Dhabi National Exhibitions Company is (100%) Holding Company of ADNEC SERVICES LLC

Please complete and return the order form to the above email address. An invoice will be dispatched in return.
Orders will be Valid only with full remittance.

Name

Date

Signature



CREDIT CARD AUTHORIZATION FORM

To be returned by via e-mail to:

ADNEC Services LLC
P.O.Box 5546, Abu Dhabi - UAE

Contact: Finance Department
Tel: + 971 02 4063653
Fax: + 971 02 4499770
Email: finance.as@adnec.ae

I hereby give ADNEC SERVICES LLC my personal permission for the following credit card guarantee and pay for:

Name /Reference: _____

Amount to be Charged: _____

Type of Credit Card: Visa Card Master Card

My Credit Card No. is: _____

Issue Date: _____

Expiry Date: _____

Signature: _____ Date: _____

Name of Credit Card Holder as it Appears on the card: _____

Company name: _____

Full Address: _____

Tel/ Fax # : _____

Email Address: _____

Payment Details: _____

Tel +971 (0) 2 406 3666 Fax +971 (0) 2 449 9770 P.O. Box 5546 Abu Dhabi



Fill & Return
adnecservices@adnec.ae



Best Price
when you pay 15 days
before the event



Standard Price
within 14 days or less prior
to the build-up days



Deadline
Submissions close 15 days prior to
the show, thereafter delivery cannot
be guaranteed and standard/on-site
price will apply

EXHIBITOR DETAILS:

Exhibiting Company Name: _____

Date: _____ Hall No. _____ Stand No. _____

** It is the exhibitor's responsibility to inform ADNEC Services of any changes to the stand number / service location.*

ORDER CONTACT DETAILS:

Full Name: _____

Job Title: _____

Company Name: _____

Company Address: _____

City: _____

Postal Code: _____

Country: _____

Contact No. _____

Email Address: _____

On-site Contact Name: _____

On-site Contact No. _____

** It is important to review TERMS AND CONDITIONS attached on this order form before submitting your order.*

INVOICE BILLING DETAILS:

Tax Registration No: _____

Same As Above

Preferred Invoice Currency: USD

AED

Full Name: _____

Job Title: _____

Company Name: _____

Company Address: _____

City: _____

Postal Code: _____

Country: _____

Contact No. _____

Email Address: _____



**ADNEC SERVICES LLC
OFFICIAL CONTRACTING
RIGGING ORDER FORM 2024**



Minimum guaranteed available rigging point heights inVenue heights) from venue floor	Standard	Requested
Exhibition Halls 1 to 11	7,000 mm	8,500 mm
Exhibition Hall 12	10,000 mm	12,000 mm

For Banner production, branding & printing enquiries please e-mail: adnecservices@adnec.ae

DESCRIPTION	STANDARD (UNIT PRICE AED)				REQUESTED (UNIT PRICE AED)				TOTAL AMOUNT
	BEST PRICE	STANDARD PRICE	ON-SITE PRICE	QTY	BEST PRICE	STANDARD PRICE	ON-SITE PRICE	QTY	
	<i>15 days prior to the event</i>	<i>14 days or less prior to the build-up days</i>	<i>during build-up days</i>		<i>15 days prior to the event</i>	<i>14 days or less prior to the build-up days</i>	<i>during build-up days</i>		
Roof Point (excludes install of third party hoists)	1,545.00	1,875.00	2,815.00		1,765.00	2,120.00	3,180.00		
Roof Point with Manual Hoist (pre-attached)	1,875.00	2,205.00	3,310.00		2,040.00	2,450.00	3,675.00		
Roof Point with Electric Chain Hoist (pre-attached c/w cables + controls)	2,205.00	2,650.00	3,975.00		2,315.00	2,780.00	4,170.00		
Install of Lightweight P.V.C. Banner up to 6m wide (less than 10kg)	1,875.00	2,250.00	3,375.00						
Exhibition Lighting	120.00	140.00	210.00						
Modular Truss System (30x30) + 20% for the black truss	130.00	156.00	235.00						
Modular Truss System (40x40) + 20% for the black truss	150.00	180.00	270.00						
Circular Truss (8mtrs)	7,000.00	8,400.00	12,600.00						
Circular Truss (6mtrs)	5,000.00	6,000.00	9,000.00						
Circular Truss (4mtrs)	3,500.00	4,200.00	6,300.00						
Drapes (Black) Hall 1-11 inclusive of installation and removal)	295.00	350.00	525.00						
Drapes (Black) Hall 12 (inclusive of installation and removal)	380.00	460.00	690.00						
Note: 50% additional surcharge for on-site orders and changes.									
GRAND TOTAL (AED)									

TERMS & CONDITIONS

1. Rigging Plans:

- All orders for rigging must follow the required guidelines and be submitted with a clear and precise rigging plan at the time of ordering. Any changes required due to incorrect rigging plans will be subject to a surcharge.
- All rigging plans must show the location of each rigging point in relation to the stand using metric measurements.
- All rigging must be within the perimeter of the stand.
- The exact weight of each rigging point must be detailed in kilograms in addition to the total weight in kilograms of the overall structure to be rigged / suspended.
- The type of structure or banner material must be detailed along with the metric width, height and length.
- The stand orientation must be detailed by showing the location of the main entrance and by the stands or walls on the other neighboring three sides.
- The height from the floor to the bottom of the structure or banner when fully suspended must be shown using metric measurements.



2. Banners:

- a. All banners must be supplied with poles in vinyl welded or sewn sleeves.
- b. All banners must be delivered two days prior to the build-up of the event. Delivery should be made to ADNEC, Monday to Friday 08:00 until 17:00 hours.
- c. All banners will be disposed of immediately after the last day of break-down unless requested.
- d. ADNEC Services are not liable for the loss and/or damage to banners during transportation, storage, installation and de-rig.

3. Installation:

- a. ADNEC Services rigging hours are Monday to Friday 08:00 until 17:00. Any request outside these hours is subject to availability and additional cost.
- b. Rigging not ready for completion by 17:00 on the last day of build-up will be the responsibility of the contractor.
- c. Any damage to ADNEC Services equipment by third party contractors will be charged.

4. Health and Safety:

- a. ADNEC Services Rigging Team is not liable for secondary rigging installed by third party contractors.
- b. During build-up, gangways must be kept clear to allow access by the rigging team.
- c. No stand structure is allowed to be attached to ADNEC ceiling as either a precautionary or additional safety measure. Ground mounted stand structures shall be so designated and constructed to be fully self-supporting.
- d. A copy of a valid hoist inspection certificate must be provided to ADNEC Services prior to installation of any hoist supplied by a third party contractor.
- e. Any structure requiring more than 4 hoists for a single lift, must use electric chain hoists.

- ADNEC Services holds the exclusive right to all primary rigging services within ADNEC.
- All rigging orders must be paid in full at the time of ordering.
- All orders must be paid 15 days before the event; standard price will apply for any unpaid orders 14 days before the event.
- All orders received after deadline date will be subject to availability of the item and standard price will apply.
- Items will not be supplied unless payment is received.
- All costs are inclusive of installation and removal.
- Cancellation or amendments to confirmed and paid orders are not permitted.
- Successful delivery of your order is dependent on the correct stand number and name of exhibiting company being provided.
- All prices, costs and charges are inclusive of 5% Value Added Tax.



Stand Orientation Grid

Hall Entrance

							▲							
							▼							

Neighboring Stand Number

Neighboring Stand Number

Neighboring Stand Number

Please ensure that any changes to the stand number or exhibiting company name are communicated to adnecservices@adnec.ae

ALL PAYMENTS MUST BE MADE PRIOR TO WORKS COMMENCING

Abu Dhabi National Exhibitions Company is (100%) Holding Company of ADNEC SERVICES LLC

Please complete and return the order form to the above email address. An invoice will be dispatched in return. Orders will be Valid only with full remittance.

Name

Date

Signature



CREDIT CARD AUTHORIZATION FORM

To be returned by via e-mail to:

ADNEC Services LLC
P.O.Box 5546, Abu Dhabi - UAE

Contact: Finance Department
Tel: + 971 02 4063653
Fax: + 971 02 4499770
Email: finance.as@adnec.ae

I hereby give ADNEC SERVICES LLC my personal permission for the following credit card guarantee and pay for:

Name /Reference: _____

Amount to be Charged: _____

Type of Credit Card: Visa Card Master Card

My Credit Card No. is: _____

Issue Date: _____

Expiry Date: _____

Signature: _____ Date: _____

Name of Credit Card Holder as it Appears on the card: _____

Company name: _____

Full Address: _____

Tel/ Fax # : _____

Email Address: _____

Payment Details: _____

ADNEC VENUE ORDER FORM 2024 CONTRACTOR & VEHICLE ACCESS (EXHIBITOR)

Form to be completed and returned to:

Email: customer.services@adnec.ae | Tel: +971 2 406 3666



EXHIBITION/EVENT INFORMATION					
Event/Exhibition Name			Date		
Hall No.		Stand No.		Stand Name	
ORDER CONTACT DETAILS					
First Name		Last Name			
Job Title					
Company Name					
Company Address					
City		Postal Code		Country	
Direct No.		Mobile No.			
Email Address					
On-site Contact Name			On-site Contact No.		

INVOICING / BILLING CONTACT DETAILS					Same as above <input type="checkbox"/>
First Name		Last Name			
Job Title					
Company Name					
Company Address					
City		Postal Code		Country	
Direct No.		Mobile No.			
Email Address					
TRN (Tax Registration No.)					

CONTRACTOR'S WRISTBAND

All contractors and vehicles must present themselves to the ADNEC holding areas access gates or loading bays. ADNEC Security and Traffic teams will administer the access process which will be directly linked with the Ministry of Immigration to ensure individuals are legally entitled to work within the UAE. The process and charges will apply to all vehicles and individuals without exception.

The process will:

- Ensure that contractors accessing the ADNEC venue are legal, legitimate, and operating within the laws of the UAE.
- Provide an accurate database of who is working within ADNEC and their reason for being in the venue.
- Increase and enhance the overall level of site security and surveillance.
- Raise awareness amongst contractors and vehicle operators to be mindful and accountable with regards to operating standards, (specifically Health & Safety considerations) and the potential impact of their work activity when on site.
- Allow greater control of the loading bays and access gates ensuring that build up and breakdown periods operate with greater efficiency.
- Ensure that vehicles and contractors adhere to the stipulated timings and rules/regulations of the venue.

ADNEC VENUE ORDER FORM 2024 CONTRACTOR & VEHICLE ACCESS (EXHIBITOR)

Form to be completed and returned to:

Email: customer.services@adnec.ae | Tel: +971 2 406 3666



Contractor's Wristband

- All contractors must present a valid Emirates ID (for UAE residents) or passport and visa copy (for international contractors) at the designated security gate each day in order to obtain the access wristband and gain access to the venue.
- Access wristbands are valid for one day only and therefore all contractors must present themselves and their information to the Security Gate on a daily basis.
- Contractor's wristband together with the official receipt will be issued upon payment of the applicable fee. Cash or Credit Card payment is accepted.
- All contractors must wear proper PPE prior to entering the loading bay. Minimum requirement includes (steel toe safety shoes, gloves, high-vis jackets, and hard hat).
- All contractors must wear their wristband at all the times while in ADNEC location. ADNEC security must be informed in case of a lost wristband. The contractor will be charged AED 25 for re-issue of wristband.
- Please note that the ADNEC Security teams monitor the build-up and venue access closely. Should they identify an individual wearing an 'Organiser' badge who is clearly involved in Contractor activities (stand construction etc.), they will be stopped and asked to follow the published process and proceed to the Security Gate to register and collect a wrist band. It is therefore very important that the correct identification badge be issued to the relevant people.
- Genuine exhibitors are exempt from the wristband process on the last day of build-up but must register with the Security Gate to obtain wristbands in the days preceding that.
- The organising team will not have to collect a wristband from the Security Gate if they have valid 'Organiser' badges. The same applies to 'Speakers' and 'Press'.
- Wristbands cannot be exchanged and are only valid for the date/s specified at the point of issue.

Contractor's Wristband is issued at the following Security Gates

- Marina Entrance - for stands located in Marina Hall.
- Security Gate 1 (located behind Hall 1) for stands located in Hall 1-4, CP1, Grandstand
- Security Gate 4 (located behind Hall 7) for stands located in Hall 5, 6, 7, 8, 9 & 10.
- Security Gate 8 (located behind Hall 10) for stands located in Hall 10, 11 & ICC.

Contractor's Wristband Charges

Description	Rate (AED)	Quantity	Total (AED)
1 Day (per pax)	25		
3 Consecutive Days (per pax)	55		
5 Consecutive Days (per pax)	90		
3 Consecutive Months	330		
Annual	550		
Show Contractor (during event open days)	225		
TOTAL (AED)			

All prices are inclusive of 5% VAT.

VEHICLE ACCESS PASS

- Every vehicle that enters the Loading Bay must be registered. (Pre-registration or onsite) This applies to every type of vehicle (Pick up and trucks)
- Filling up Preregistration will not provide priority to access the loading area but enable to speed up the process at the entry.
- All vehicles must go to the Holding area first and then will be directed to the relevant Loading bays.
- The Holding area is the only place where a vehicle can obtain the entry permission- Loading Bay pass.
- Our traffic marshals will direct you to the precise location for parking.
- Please use separate preregistration forms for buildup & breakdown period
- Vehicles on loading bays without information will be fined AED 300 and authorities will be informed to remove such vehicles from the loading bay.
- Materials to be carried by hand are not allowed to use loading bays but need to use multi-storey car park.
- In the circumstance of vehicle using additional time to the booked period in the pre-registration form, additional amount will be needed to pay at the time of exit.

ADNEC VENUE ORDER FORM 2024 CONTRACTOR & VEHICLE ACCESS (EXHIBITOR)

Form to be completed and returned to:

Email: customer.services@adnec.ae | Tel: +971 2 406 3666



ADNEC BANKING DETAILS

- Please complete this Form and submit it to Customer Services (customer.services@adnec.ae).
- An invoice will be dispatched in return. Orders will be considered valid only once full payment has been received.
- If payment has been made prior to invoicing, please send a copy of proof of payment to ADNEC Receivables (receivables@adnec.ae); Customer Services (customer.services@adnec.ae).
- Payment can be made by Credit Card, Bank Transfer, or Company Cheque.
- Email correspondence regarding payment and invoicing should be sent to ADNEC Receivables (receivables@adnec.ae); Customer Services (customer.services@adnec.ae) to be included in any correspondence.

PAYMENT METHOD

CREDIT CARD

On selecting this method, ADNEC Receivables will email the "Credit Card Authorization Form". This form should be filled and returned to receivables@adnec.ae to signify the approval of processing the payment.

BANK TRANSFER

Payment net of bank charges should be made in favour of Abu Dhabi National Exhibition Company to the following account. Please allow five (5) working days to ensure that the funds have cleared on time. Note that bank charges should be borne by the client.

AED Account Name: Abu Dhabi National Exhibition Co.
Bank Name: First Abu Dhabi Bank
Account No: 4021003067462010
IBAN No: AE590354021003067462010
Swift Code: NBADAEAXXX

USD Account Name: Abu Dhabi National Exhibition Co.
Bank Name: First Abu Dhabi Bank
Account No: 4021003067462123
IBAN No: AE150354021003067462123
Swift Code: NBADAEAXXX

COMPANY CHEQUE

This mode of payment is only applicable to companies based in UAE. Please allow 5 working days to ensure that the funds have cleared on time, and as such postdated cheques are not accepted. Please send a copy of the cheque or transmission slip for cheques deposited a day or on the day of the event. Cheque should be made payable to:

Abu Dhabi National Exhibitions Company
PO Box 5546, Abu Dhabi, United Arab Emirates

ADNEC Group TRN (Tax Registration Number): 100305367300003

Name _____ Signature _____ Date _____

ADNEC VENUE ORDER FORM 2024 PARKING (EXHIBITOR)

Form to be completed and returned to:

Email: customer.services@adnec.ae | Tel: +971 2 406 3666



EXHIBITION/EVENT INFORMATION				
Event/Exhibition Name		Date		
Hall No.	Stand No.	Stand Name		
ORDER CONTACT DETAILS				
First Name		Last Name		
Job Title				
Company Name				
Company Address				
City	Postal Code	Country		
Direct No.	Mobile No.			
Email Address				
On-site Contact Name		On-site Contact No.		

INVOICING / BILLING CONTACT DETAILS					Same as above <input type="checkbox"/>
First Name		Last Name			
Job Title					
Company Name					
Company Address					
City	Postal Code	Country			
Direct No.	Mobile No.				
Email Address					
TRN (Tax Registration No.)					

PARKING	UNIT PRICE (AED)	QUANTITY	TOTAL (AED)
Daily Car Park Ticket – Car Park A or B only (per space per day)	80		
VIP Parking (per space, per day)	150		
TOTAL (AED)			

All prices are inclusive of 5% VAT.

TERMS AND CONDITIONS

- Daily Car Park Tickets are valid in the ADNEC Multi-Storey Car park A or B only.
- Each ticket is valid for one day only.
- Overnight parking is not allowed.
- Please do not park in restricted/reserved parking spaces within the ADNEC Multi-Storey Car Park A or B.
- ADNEC reserves the right to refuse entry to the Multi-Storey Car Park A and B.
- ADNEC reserves the right to move any vehicle that is parked in contravention of the above terms and conditions or is otherwise causing an obstruction or the general operation of the Car Park.

ADNEC VENUE ORDER FORM 2024 PARKING (EXHIBITOR)

Form to be completed and returned to:

Email: customer.services@adnec.ae | Tel: +971 2 406 3666



ADNEC BANKING DETAILS

- Please complete this Form and submit it to Customer Services (customer.services@adnec.ae).
- An invoice will be dispatched in return. Orders will be considered valid only once full payment has been received.
- If payment has been made prior to invoicing, please send a copy of proof of payment to ADNEC Receivables (receivables@adnec.ae); Customer Services (customer.services@adnec.ae).
- Payment can be made by Credit Card, Bank Transfer, or Company Cheque.
- Email correspondence regarding payment and invoicing should be sent to ADNEC Receivables (receivables@adnec.ae); Customer Services (customer.services@adnec.ae) to be included in any correspondence.

PAYMENT METHOD

CREDIT CARD

On selecting this method, ADNEC Receivables will email the "Credit Card Authorization Form". This form should be filled and returned to receivables@adnec.ae to signify the approval of processing the payment.

BANK TRANSFER

Payment net of bank charges should be made in favour of Abu Dhabi National Exhibition Company to the following account. Please allow five (5) working days to ensure that the funds have cleared on time. Note that bank charges should be borne by the client.

AED Account Name: Abu Dhabi National Exhibition Co.
Bank Name: First Abu Dhabi Bank
Account No: 4021003067462010
IBAN No: AE590354021003067462010
Swift Code: NBADAEAXXX

USD Account Name: Abu Dhabi National Exhibition Co.
Bank Name: First Abu Dhabi Bank
Account No: 4021003067462123
IBAN No: AE150354021003067462123
Swift Code: NBADAEAXXX

COMPANY CHEQUE

This mode of payment is only applicable to companies based in UAE. Please allow 5 working days to ensure that the funds have cleared on time, and as such postdated cheques are not accepted. Please send a copy of the cheque or transmission slip for cheques deposited a day or on the day of the event. Cheque should be made payable to:

Abu Dhabi National Exhibitions Company
PO Box 5546, Abu Dhabi, United Arab Emirates

ADNEC Group TRN (Tax Registration Number): 100305367300003

Name _____ Signature _____ Date _____

ADNEC VENUE ORDER FORM 2024

SKIP HIRE (EXHIBITOR)

Form to be completed and returned to:

Email: customer.services@adnec.ae | Tel: +971 2 406 3666



EXHIBITION/EVENT INFORMATION

Event/Exhibition Name		Date	
Hall No.		Stand No.	
		Stand Name	

ORDER CONTACT DETAILS

First Name		Last Name	
Job Title			
Company Name			
Company Address			
City		Postal Code	
		Country	
Direct No.		Mobile No.	
Email Address			
On-site Contact Name		On-site Contact No.	

INVOICING / BILLING CONTACT DETAILS Same as above

First Name		Last Name	
Job Title			
Company Name			
Company Address			
City		Postal Code	
		Country	
Direct No.		Mobile No.	
Email Address			
TRN (Tax Registration No.)			

Description	Date/s Required	Quantity	Rate (AED)	Total (AED)
20 cubic metres waste disposal skips			2,144 per skip	
TOTAL (AED)				

All prices are inclusive of 5% VAT.

WASTE DECLARATION

Paper	<input type="text"/>	Brick	<input type="text"/>
Cardboard	<input type="text"/>	Metal	<input type="text"/>
Plastic	<input type="text"/>	Wood	<input type="text"/>
Food	<input type="text"/>	Soil	<input type="text"/>

ADNEC VENUE ORDER FORM 2024

SKIP HIRE (EXHIBITOR)

Form to be completed and returned to:

Email: customer.services@adnec.ae | Tel: +971 2 406 3666



TERMS AND CONDITIONS

- All orders will be subject to availability and will be served on a priority basis.
- For confirmed orders a minimum of 12 hours will be required to deliver the skip on site.
- For Hazardous / Medical waste Exhibitor must declare the details of the waste prior to disposal to ADNEC Cleaning Department. Special quotations will be provided for the requirement.
- It is your responsibility as the producer of waste to notify ADNEC Cleaning Department of any problem with storage handling or disposal of waste.

ADNEC BANKING DETAILS

- Please complete this Form and submit it to Customer Services (customer.services@adnec.ae).
- An invoice will be dispatched in return. Orders will be considered valid only once full payment has been received.
- If payment has been made prior to invoicing, please send a copy of proof of payment to ADNEC Receivables (receivables@adnec.ae); Customer Services (customer.services@adnec.ae).
- Payment can be made by Credit Card, Bank Transfer, or Company Cheque.
- Email correspondence regarding payment and invoicing should be sent to ADNEC Receivables (receivables@adnec.ae); Customer Services (customer.services@adnec.ae) to be included in any correspondence.

PAYMENT METHOD

CREDIT CARD

On selecting this method, ADNEC Receivables will email the "Credit Card Authorization Form". This form should be filled and returned to receivables@adnec.ae to signify the approval of processing the payment.

BANK TRANSFER

Payment net of bank charges should be made in favour of Abu Dhabi National Exhibition Company to the following account. Please allow five (5) working days to ensure that the funds have cleared on time. Note that bank charges should be borne by the client.

AED Account Name: Abu Dhabi National Exhibition Co.
Bank Name: First Abu Dhabi Bank
Account No: 4021003067462010
IBAN No: AE590354021003067462010
Swift Code: NBADAEAXXX

USD Account Name: Abu Dhabi National Exhibition Co.
Bank Name: First Abu Dhabi Bank
Account No: 4021003067462123
IBAN No: AE150354021003067462123
Swift Code: NBADAEAXXX

COMPANY CHEQUE

This mode of payment is only applicable to companies based in UAE. Please allow 5 working days to ensure that the funds have cleared on time, and as such postdated cheques are not accepted. Please send a copy of the cheque or transmission slip for cheques deposited a day or on the day of the event. Cheque should be made payable to:

Abu Dhabi National Exhibitions Company
PO Box 5546, Abu Dhabi, United Arab Emirates

ADNEC Group TRN (Tax Registration Number): 100305367300003

Name _____ Signature _____ Date _____

ADNEC VENUE ORDER FORM 2024

STAND CLEANING (EXHIBITOR)

Form to be completed and returned to:

Email: customer.services@adnec.ae | Tel: +971 2 406 3666



EXHIBITION/EVENT INFORMATION

Event/Exhibition Name			Date	
Hall No.		Stand No.		Stand Name

ORDER CONTACT DETAILS

First Name			Last Name		
Job Title					
Company Name					
Company Address					
City		Postal Code		Country	
Direct No.		Mobile No.			
Email Address					
On-site Contact Name			On-site Contact No.		

INVOICING / BILLING CONTACT DETAILS Same as above

First Name			Last Name		
Job Title					
Company Name					
Company Address					
City		Postal Code		Country	
Direct No.		Mobile No.			
Email Address					
TRN (Tax Registration No.)					

NOTE: The charges for cleaning Space Only Stands are based on a flat rate of AED 43 / 48 / 48 x total square metres of stand space for the complete open period of the event.

Cleaning Service for Space Only / Shell Scheme Stand	Early Bird (AED) (30 days prior to event opening)	Standard (AED) (14 days prior to event opening)	Last Minute (AED) (13 days prior to event opening)	Area (Sq M)	Total (AED)
Space Only Stands (Total ground level square metres)	43	48	48		
Space Only Stands (Total first floor square metres)	43	48	48		
Shell Scheme stand (above 18 sqm)	43	48	48		
SUBTOTAL					

All prices are inclusive of 5% VAT.

ADNEC VENUE ORDER FORM 2024

STAND CLEANING (EXHIBITOR)

Form to be completed and returned to:

Email: customer.services@adnec.ae | Tel: +971 2 406 3666



Valet Cleaning Services	Early Bird Price (AED) (30 days prior to event opening)	Standard Price (AED) (14 days prior to event opening)	No. of Hours	No. of Staff	No. of Days	Total (AED)
Cleaning Attendant during event open hours only (AED 340 or 390 for 8 hours) (This request can only be applied with cleaning request for stand space). Please note: Minimum of 8 hours is chargeable for each request per day.	340	390				
Cleaning attendant – Additional hours (per hour)	43	48				
SUBTOTAL						

TOTAL (AED)	
--------------------	--

TIMINGS FOR VALET CLEANING SERVICES						
Date	Day	Start Time	End Time	No. of Staff	No. of Hours	Total Hours
TOTAL HOURS						

TERMS AND CONDITIONS:

- Orders received less than 14 days prior to the event will be subject to availability.
- Orders received after the above-mentioned deadline cannot be guaranteed of the service being provided.
- Shell Scheme Stands below 18 m2 will not be charged for standard cleaning services.
- Stand Cleaning includes vacuuming or wet mopping of floors; dusting of counter tops and furniture; emptying of bins, cleaning of walls, glass and partitions (except exhibits).
- Double Decker Stands will be charged on the total floor space per m2.
- All cleaning is carried out at night, not during the exhibition opening hours, to ensure the stands are ready prior to the opening of the exhibition. It will be performed on the night before the opening day of the event and each night thereafter.
- The Timing for Valet Cleaning Service must be determined, if not, Valet Cleaning Service will be provided 1 hour before the show opening time.
- Valet Cleaning Service does not include provision of cleaning consumables such as hand soap, hand sanitiser, toilet rolls, C-fold tissue paper, etc.
- The role of the Valet Cleaner is to ensure that your stand is always kept clean and presentable and free from the accumulation of waste.
- ADNEC Cleaning Department cannot be held liable for any loss or damage related to the cleaning of the exhibition stand.
- ADNEC Cleaning Department does not supply cleaning materials to exhibitors or their contractors.
- To guarantee quality of service, exhibition stands must be clear of all contractors' work and materials by midnight on the last day of build-up.
- Disposal of catering waste is not the responsibility of ADNEC Cleaning Services.

ADNEC VENUE ORDER FORM 2024

STAND CLEANING (EXHIBITOR)

Form to be completed and returned to:

Email: customer.services@adnec.ae | Tel: +971 2 406 3666



ADNEC BANKING DETAILS

- Please complete this Form and submit it to Customer Services (customer.services@adnec.ae).
- An invoice will be dispatched in return. Orders will be considered valid only once full payment has been received.
- If payment has been made prior to invoicing, please send a copy of proof of payment to ADNEC Receivables (receivables@adnec.ae); Customer Services (customer.services@adnec.ae).
- Payment can be made by Credit Card, Bank Transfer, or Company Cheque.
- Email correspondence regarding payment and invoicing should be sent to ADNEC Receivables (receivables@adnec.ae); Customer Services (customer.services@adnec.ae) to be included in any correspondence.

PAYMENT METHOD

CREDIT CARD

On selecting this method, ADNEC Receivables will email the "Credit Card Authorization Form". This form should be filled and returned to receivables@adnec.ae to signify the approval of processing the payment.

BANK TRANSFER

Payment net of bank charges should be made in favour of Abu Dhabi National Exhibition Company to the following account. Please allow five (5) working days to ensure that the funds have cleared on time. Note that bank charges should be borne by the client.

AED Account Name: Abu Dhabi National Exhibition Co.
Bank Name: First Abu Dhabi Bank
Account No: 4021003067462010
IBAN No: AE590354021003067462010
Swift Code: NBADAEAXXX

USD Account Name: Abu Dhabi National Exhibition Co.
Bank Name: First Abu Dhabi Bank
Account No: 4021003067462123
IBAN No: AE150354021003067462123
Swift Code: NBADAEAXXX

COMPANY CHEQUE

This mode of payment is only applicable to companies based in UAE. Please allow 5 working days to ensure that the funds have cleared on time, and as such postdated cheques are not accepted. Please send a copy of the cheque or transmission slip for cheques deposited a day or on the day of the event. Cheque should be made payable to:

Abu Dhabi National Exhibitions Company
PO Box 5546, Abu Dhabi, United Arab Emirates

ADNEC Group TRN (Tax Registration Number): 100305367300003

Name _____ Signature _____ Date _____

ADNEC VENUE ORDER FORM 2024

STATIC SECURITY (EXHIBITOR)

Form to be completed and returned to:

Email: customer.services@adnec.ae | Tel: +971 2 406 3666



EXHIBITION/EVENT INFORMATION

Event/Exhibition Name		Date	
Hall No.		Stand No.	
		Stand Name	

ORDER CONTACT DETAILS

First Name		Last Name	
Job Title			
Company Name			
Company Address			
City		Postal Code	
			Country
Direct No.		Mobile No.	
Email Address			
On-site Contact Name		On-site Contact No.	

INVOICING / BILLING CONTACT DETAILS Same as above

First Name		Last Name	
Job Title			
Company Name			
Company Address			
City		Postal Code	
			Country
Direct No.		Mobile No.	
Email Address			
TRN (Tax Registration No.)			

All prices are inclusive of 5% VAT.

Security Manning Services	Early Bird Price (AED) (Before 14 days from event date)	StandardPrice(AED) (Within 14 days or less)	Total Hours	Total (AED)
Static Male Security Guard	97	116		
Static Female Security Guard	97	116		
Bouncer	139	174		
			Subtotal	

Please note: A minimum of 8 hours is chargeable for each security manning request per day.

Other Services	Qty.	Early Bird Price (AED) (Before 14 days from event date)	StandardPrice(AED) (Within 14 days or less)	Total (AED)
Rental of Tensator Barriers (Duration of Event) (H:95cm W:2m)		67	80	
Rental of Metal Barrier (Duration of Event) (H:1m W:2.6m)		67	80	
			Subtotal	
			TOTAL	

ADNEC VENUE ORDER FORM 2024 STATIC SECURITY (EXHIBITOR)

Form to be completed and returned to:

Email: customer.services@adnec.ae | Tel: +971 2 406 3666



Please note:

- All orders will be subject to availability.
- Static Security Guards – 24-hour services can be provided as per your requirement.
- Abu Dhabi National Exhibition Company has the exclusive rights for security services inside the halls.
- The Static Security Guard is not part of the hall's rental services.

REQUIREMENTS							
Date	Day	Type of Manning Service	StartTime	End Time	No. of Guards	No. of Hours	Total Hours
TOTAL MANHOURS							

ADNEC BANKING DETAILS

- Please complete this Form and submit it to Customer Services (customer.services@adnec.ae).
- An invoice will be dispatched in return. Orders will be considered valid only once full payment has been received.
- If payment has been made prior to invoicing, please send a copy of proof of payment to ADNEC Receivables (receivables@adnec.ae); Customer Services (customer.services@adnec.ae).
- Payment can be made by Credit Card, Bank Transfer, or Company Cheque.
- Email correspondence regarding payment and invoicing should be sent to ADNEC Receivables (receivables@adnec.ae); Customer Services (customer.services@adnec.ae) to be included in any correspondence.

PAYMENT METHOD

CREDIT CARD

On selecting this method, ADNEC Receivables will email the "Credit Card Authorization Form". This form should be filled and returned to receivables@adnec.ae to signify the approval of processing the payment.

BANK TRANSFER

Payment net of bank charges should be made in favour of Abu Dhabi National Exhibition Company to the following account. Please allow five (5) working days to ensure that the funds have cleared on time. Note that bank charges should be borne by the client.

AED Account Name: Abu Dhabi National Exhibition Co.
Bank Name: First Abu Dhabi Bank
Account No: 4021003067462010
IBAN No: AE590354021003067462010
Swift Code: NBADAEAXXX

USD Account Name: Abu Dhabi National Exhibition Co.
Bank Name: First Abu Dhabi Bank
Account No: 4021003067462123
IBAN No: AE150354021003067462123
Swift Code: NBADAEAXXX

COMPANY CHEQUE

This mode of payment is only applicable to companies based in UAE. Please allow 5 working days to ensure that the funds have cleared on time, and as such postdated cheques are not accepted. Please send a copy of the cheque or transmission slip for cheques deposited a day or on the day of the event. Cheque should be made payable to:

Abu Dhabi National Exhibitions Company
PO Box 5546, Abu Dhabi, United Arab Emirates

ADNEC Group TRN (Tax Registration Number): 100305367300003

Name _____ Signature _____ Date _____

TELECOMS SERVICES EXHIBITORS IT ORDER FORM 2024

Form to be completed and returned to ADNEC Customer Services
(customer.services@adnec.ae) | +971 2 406 3666



Part of ADNEC GROUP

Your trusted partner for innovative & reliable telecommunication experiences via high-quality services delivered with passion and commitment.



Fill & Return
telecoms@adnec.ae



Best Price

when you pay 14 days before
the event date



Standard Price

when you pay within 14 days or
less from the event date



Deadline

Submission 2 Days prior to the
show will not guarantee the
delivery of the services and will
result in 50% additional surcharge
for on-site orders and changes

EXHIBITION/EVENT INFORMATION:

Exhibition / Event Name: _____

Date: _____ Hall No. _____

Stand No.: _____ Stand Name _____

ORDER CONTACT DETAILS:

Full Name: _____

Last Name: _____

Job Title: _____

Company Name: _____

Company Address: _____

Direct No. _____

Mobile No. _____

Email Address: _____

INVOICE BILLING DETAILS:

**Abu Dhabi National Exhibitions Company is (100%) Holding Company
of ADNEC SERVICES LLC**

Please complete and return the order form to the above email address. An invoice will be
dispatched in return. Orders will be Valid only with full remittance

CREDIT CARD

On selecting this method, ADNEC Receivables will email the "Credit Card Authorization Form".
This form should be filled and returned back to finance.as@adnec.ae to signify the approval
of processing the payment

Cheque & Bank Draft

ADNEC SERVICES L.L.C. - P.O. Box 5546 Abu Dhabi, UAE

Bank Transfers should be made, net of bank charges through the following account:

AED

Account Name : ADNEC SERVICES L.L.C.

Bank : FIRST ABU DHABI BANK

Account No. : 4021003733279010

Swift Code : NBADAEAXXX

IBAN No. : AE440354021003733279010

USD

Account Name : ADNEC SERVICES L.L.C.

Bank : FIRST ABU DHABI BANK

Account No. : 4021003733279021

Swift Code : NBADAEAXXX

IBAN No. : AE380354021003733279021

TAX REGISTRATION NUMBER: 100305367300003

NOTE: For International clients it is important that you use the IBAN No. for all the remittances.
Copy of the confirmed transfer must be sent to finance.as@adnec.ae

THIS PRICE LIST IS VALID FOR THE PERIOD 1 JANUARY - 31 DECEMBER 2024 | ALL PRICES ARE INCLUSIVE OF VAT.

TELECOMS SERVICES EXHIBITORS IT ORDER FORM 2024



Form to be completed and returned to ADNEC Customer Services
(customer.services@adnec.ae) | +971 2 406 3666

Part of ADNEC GROUP

WIRELESS VOUCHERS

For individual Internet access, not recommended for high throughput demonstration or file download.

Note: 50% additional surcharge for on-site orders and changes

ITEM DESCRIPTION	INTERNET SPEED	EARLY BIRD (AED)	STANDARD PRICE (AED)	QTY	TOTAL
Open Air WiFi Access - 2 Hours	5Mbps	24.00	28.80		
Open Air WiFi Access - 8 Hours	5Mbps	87.00	104.40		
Open Air WiFi Access - 24 Hours	5Mbps	122.00	146.40		

INTERNET CONNECTIONS (WIRED OR WIRELESS)

- Internet will be provided with username and password. The default SSID to connect is Premium Wi-Fi.
- A fee of AED 331 will be charged for each change to the location of a fixed line/ wired connectivity.
- If wired option is selected, there will be 1 cable provided only with on-site assistance. If additional cables are required, please look at Network Equipment.
- If wired Internet is selected, a copy of the marked location via floorplan must be presented to ensure the delivery of the service.
- These Internet Lines will include 100% Download Speed and 20% Upload Speed.

ITEM DESCRIPTION	INTERNET SPEED	CONNECTIVITY TYPE	EARLY BIRD (AED)	STANDARD PRICE (AED)	QTY	TOTAL
<input type="checkbox"/> 5 Internet Connections	30Mbps	<input type="checkbox"/> Wired <input type="checkbox"/> Wireless	4,255.00	5106.00		
<input type="checkbox"/> 15 Internet Connections	50Mbps	<input type="checkbox"/> Wired <input type="checkbox"/> Wireless	5,469.00	6,562.80		
<input type="checkbox"/> 30 Internet Connections	80Mbps	<input type="checkbox"/> Wired <input type="checkbox"/> Wireless	7,900.00	9,480.00		
<input type="checkbox"/> 50 Internet Connections	120Mbps	<input type="checkbox"/> Wired <input type="checkbox"/> Wireless	10,332.00	12,398.40		
<input type="checkbox"/> 100 Internet Connections	150Mbps	<input type="checkbox"/> Wired <input type="checkbox"/> Wireless	12,763.00	15,315.60		

*All connections have automatic IP addressing. If you need a Static IP, please tick here

NETWORK & COMMUNICATIONS EQUIPMENT

ITEM DESCRIPTION	EARLY BIRD (AED)	STANDARD PRICE (AED)	DESCRIPTION	QTY	TOTAL
Network Cable drop	420.00	504.00	To link multiple locations together on a single network. Subject to availability in locations identified		
Fibre Core	2,431.00	2,917.20	Fibre Core is available inside the venue only. Additional cost will be provided through separate quotation.		
IPTV	2,431.00	2,917.20	ADNEC IT provides the Satellite TV Box. The requester should arrange for a TV, HDMI cable and a POWER.		

THIS PRICE LIST IS VALID FOR THE PERIOD 1 JANUARY - 31 DECEMBER 2024 | ALL PRICES ARE INCLUSIVE OF VAT.

TELECOMS SERVICES EXHIBITORS IT ORDER FORM 2024

Form to be completed and returned to ADNEC Customer Services
(customer.services@adnec.ae) | +971 2 406 3666



Part of ADNEC GROUP

LAPTOP, SWITCHES AND ETHERNET CABLES

ITEM DESCRIPTION	EARLY BIRD (AED)	STANDARD PRICE (AED)	QTY	TOTAL
Laptop	750.00	900.00		
Switch - 8Port	486.00	583.20		
Switch - 16Port	730.00	876.00		
Switch - 24Port	972.00	1,166.40		
2M - Ethernet Cable	18.00	21.60		
3M - Ethernet Cable	51.00	61.20		
5M - Ethernet Cable	69.00	82.80		
10M - Ethernet Cable	105.00	126.00		
20M - Ethernet Cable	162.00	194.40		
POE - 8Port	735.00	882.00		
POE - 16Port	1,155.00	1,386.00		
POE - 24Port	1,365.00	1,638.00		

INTERNET LEASED LINE SERVICE (PUBLIC IP)

- A minimum of 30 working days is required to deliver this service. If ordered on-site, service availability and delivery are not guaranteed.
- Internet service will be delivered by WIRED only. Each option comes with four (4) public IP address
- Internet line which will provide equal Download & Upload Speed . (Recommended for broadcasting, live streaming, web conferences, Fixed IP)

ITEM DESCRIPTION	PRICE (AED)	QTY	TOTAL
<input type="checkbox"/> 5Mbps	10,500.00		
<input type="checkbox"/> 10Mbps	16,500.00		

MANPOWER

Dedicated IT Support Engineer and Cabling Technicians can be provided, on a daily rate.

ITEM DESCRIPTION	EARLY BIRD (AED)	STANDARD PRICE (AED)	QTY	TOTAL
<input type="checkbox"/> IT Support Engineer	799.00	958.80		
<input type="checkbox"/> Cabling Technician	365.00	438.00		

THIS PRICE LIST IS VALID FOR THE PERIOD 1 JANUARY - 31 DECEMBER 2024 | ALL PRICES ARE INCLUSIVE OF VAT.

TELECOMS SERVICES EXHIBITORS IT ORDER FORM 2024

Form to be completed and returned to ADNEC Customer Services
(customer.services@adnec.ae) | +971 2 406 3666



Part of ADNEC GROUP

TELEPHONE AND FAX

- Point of Sales (POS) and Credit Card machines are not provided.
- When Telephone service is selected, the line will be local by default unless International is selected.

ITEM DESCRIPTION	EARLY BIRD (AED) WITHIN 14 DAYS OR LESS	STANDARD PRICE(AED) WITHIN 14 DAYS OR LESS	QTY	TOTAL
<input type="checkbox"/> Telephone <input type="checkbox"/> International	730.00	876.00		
<input type="checkbox"/> Conference Telephone <input type="checkbox"/> International	1,338.00	1,605.60		
<input type="checkbox"/> Point Of Sales (POS) / Credit Card Lines	730.00	876.00		
ISDN 128Kbps (2B + D) Digital	1,824.00	2,188.80		
Conferences over Virtual Environment (Teams, Zoom Calls)	POA	POA		

*Refundable Deposit (Applicable to the first Telephone POS or ISDN line ordered only)

*Telephone Outgoing call charges (as per Etisalat Standard call rates; statement to be shared after the event)

TERMS & CONDITIONS

By affixing my signature, I hereby confirm that I have read and agreed to the Terms and Conditions stated below:

NAME	GRAND TOTAL
Signature	
Date	

- ADNEC Services Telecoms holds the exclusive rights to all data and telecommunication services within the venue.
- All orders received after deadline date will be subject to availability of the item and standard price will apply.
- Cancellation to confirmed or paid orders are permitted, however, service fee of 50% will be deducted.
- Payment Refund will ONLY be entertained upon receipt of written request, subject to Management approval.
- ADNEC Services Telecoms is not responsible to configure or support any personal devices owned by the client.
- Exhibitors are responsible on IT equipment supplied by ADNEC. Any loss or damage to the equipment will be charged.
- Order Form has to be filled properly and submitted to ADNEC Customer Services (customer.services@adnec.ae)
- Duration of all IT Services (except Open Air vouchers and Bulk Order Wireless Access) are valid for 30 calendar days only.
- ADNEC operates on 5GHz wireless frequency only. Private wireless broadcasts are not permitted within ADNEC. Non- ADNEC wireless broadcasts will be ceased in order to mitigate wireless signal interference and any devices used will be switched off immediately.
- Negligence in router usage, including violations of the policy, will not be taken lightly. In accordance with our organization's policies, repeated or severe violations may result in disciplinary actions, and fines may be imposed to cover the costs associated with rectifying any damages caused.
- ADNEC Services Telecoms provides quality services to its customers, maximize their investment in IT Technology, provide cost effective IT support and delivery of IT services and implement IT best practices to satisfy business units. Copy of the ADNEC Information Technology Service Management System Policy is available upon request.

THIS PRICE LIST IS VALID FOR THE PERIOD 1 JANUARY - 31 DECEMBER 2024 | ALL PRICES ARE INCLUSIVE OF VAT.

ADNEC VENUE ORDER FORM 2024

VEHICLE CLEANING (EXHIBITOR)

Form to be completed and returned to:

Email: customer.services@adnec.ae | Tel: +971 2 406 3666



EXHIBITION/EVENT INFORMATION					
Event/Exhibition Name				Date	
Hall No.		Stand No.		Stand Name	
ORDER CONTACT DETAILS					
First Name				Last Name	
Job Title					
Company Name					
Company Address					
City		Postal Code		Country	
Direct No.		Mobile No.			
Email Address					
On-site Contact Name				On-site Contact No.	

INVOICING / BILLING CONTACT DETAILS						Same as above <input type="checkbox"/>
First Name				Last Name		
Job Title						
Company Name						
Company Address						
City		Postal Code		Country		
Direct No.		Mobile No.				
Email Address						
TRN (Tax Registration No.)						

Description	Price (AED)	Number of Vehicles to be Cleaned	Total (AED)
Cleaning - Small Vehicle (1m to 5m)	244		
Cleaning - Medium Vehicle (5.1m to 8m)	365		
Cleaning - Large Vehicle (8.1m to 10m)	486		
TOTAL (AED)			

All prices are inclusive of 5% VAT.

TERMS AND CONDITIONS

- Orders received less than 14 days prior to the event will be subject to availability.
- Cleaning is carried out at night, not during the exhibition opening hours. It will be performed on the night before the opening day of the event and each night thereafter.
- ADNEC Cleaning Department cannot be held liable for any loss or damage related to the cleaning of the vehicle.
- ADNEC Cleaning Department does not supply cleaning materials to exhibitors or their contractors.
- To guarantee quality of service, exhibition stands must be clear of all contractors' work and materials by midnight on the last day of build-up.

ADNEC VENUE ORDER FORM 2024

VEHICLE CLEANING (EXHIBITOR)

Form to be completed and returned to:

Email: customer.services@adnec.ae | Tel: +971 2 406 3666



ADNEC BANKING DETAILS

- Please complete this Form and submit it to Customer Services (customer.services@adnec.ae).
- An invoice will be dispatched in return. Orders will be considered valid only once full payment has been received.
- If payment has been made prior to invoicing, please send a copy of proof of payment to ADNEC Receivables (receivables@adnec.ae); Customer Services (customer.services@adnec.ae).
- Payment can be made by Credit Card, Bank Transfer, or Company Cheque.
- Email correspondence regarding payment and invoicing should be sent to ADNEC Receivables (receivables@adnec.ae); Customer Services (customer.services@adnec.ae) to be included in any correspondence.

PAYMENT METHOD

CREDIT CARD

On selecting this method, ADNEC Receivables will email the "Credit Card Authorization Form". This form should be filled and returned to receivables@adnec.ae to signify the approval of processing the payment.

BANK TRANSFER

Payment net of bank charges should be made in favour of Abu Dhabi National Exhibition Company to the following account. Please allow five (5) working days to ensure that the funds have cleared on time. Note that bank charges should be borne by the client.

AED Account Name: Abu Dhabi National Exhibition Co.
Bank Name: First Abu Dhabi Bank
Account No: 4021003067462010
IBAN No: AE590354021003067462010
Swift Code: NBADAEAXXX

USD Account Name: Abu Dhabi National Exhibition Co.
Bank Name: First Abu Dhabi Bank
Account No: 4021003067462123
IBAN No: AE150354021003067462123
Swift Code: NBADAEAXXX

COMPANY CHEQUE

This mode of payment is only applicable to companies based in UAE. Please allow 5 working days to ensure that the funds have cleared on time, and as such postdated cheques are not accepted. Please send a copy of the cheque or transmission slip for cheques deposited a day or on the day of the event. Cheque should be made payable to:

Abu Dhabi National Exhibitions Company
PO Box 5546, Abu Dhabi, United Arab Emirates

ADNEC Group TRN (Tax Registration Number): 100305367300003

Name _____ Signature _____ Date _____